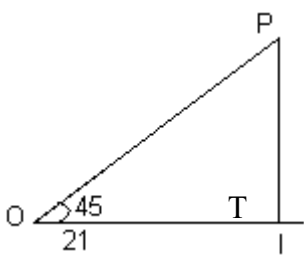

**FORM 4
MATHEMATICS PAPER II MARKING SCHEME.**

SECTION I (50 MKS)

1.	$x + 5 = \frac{4}{x + 2}$ $x^2 + 7x + 6 = 0$ $x^2 + 6x + x + 6 = 0$ $(x + 6)(x + 1) = 0$ $x = -6 \text{ or } -1$	M1 M1 A1	
		3	
2.	$2x^2 + 2y^2 + 6x - 10y + 7 \text{ and}$ $x^2 + y^2 + 8x - 2y + 4 = 0$ <p style="text-align: center;"> A B </p> <p>Centre (-1.5, 2.5) (-4, 1)</p> <p>Distance =</p> $\sqrt{(-4 - (-1.5))^2 + (1 - 2.5)^2}$ $= \sqrt{(-2.5)^2 + (-1.5)^2}$ $= \sqrt{6.25 + 2.25}$ $= \sqrt{8.5}$ $= 2.9155$ <p style="text-align: right;">$= 2.92$</p>	B1 B1 M1 A1	Centre A obtained Centre B obtained Finding the modulus
		4	
3.	$a^2 = \frac{s^2 + q}{p^2}$ $a^2 p^2 = s^2 + q$ $s^2 = a^2 p^2 - q$ $s = \pm \sqrt{a^2 p^2 - q}$	M1 M1 A1	
		3	
4.			

	$PT = 21 \tan 60'$ $PT = 36.37$ $\text{Area of PTOR} = 2 \times \left(\frac{1}{2} (36.37 \times 21) \right)$ $= 763.77 \text{ cm}$ $\text{Area of the sector ROT} = \frac{120}{360} \times \frac{22}{7} \times 21 \times 21$ $= 462$ $\text{Area of the shaded part}$ $763.77 - 462$ $= 301.77 \text{ cm}^2$	B ₁ B ₁ A ₁	
		3	
5.	The terms are $8+2d, 8+4d, 8+7d$ $\frac{8+4d}{8+2d} = \frac{8+7d}{8+4d}$ $(8+4d)^2 = (8+2d)(8+7d)$ $2d^2 - 8d = 0$ $2d(d-4) = 8$ $d = 4$ $r = \frac{8 + (4 \times 4)}{8 + (2 \times 4)}$ $= \frac{32}{16} = \frac{3}{2} \text{ or } 1\frac{1}{2}$	M ₁ A ₁ B ₁	For equating Value of d Value of r
6	$900 = \frac{\theta}{360} \times 2 \times 3.142 \times 6370$ $\theta = \frac{900 \times 360}{6.284 \times 6370}$ $= 8.09^\circ$ $\text{latitude} = 8.09 - 5$ 3.1°S	M ₁ A ₁ B ₁	
		3	
7	$1049404 = 600000 \left(1 + \frac{15}{100} \right)^n$ $1.7490066 = (1.15)^n$ $\log 1.7490066 = n \log 1.15$	M ₁ M ₁	Substitution Logs taken both sides

	$\frac{\log 1.74900666}{\log 1.15} = n$ $n = 4 \text{ years}$	A1	
		3	
8	$A = mB + n\sqrt{B}$ $22 = 4m + 2n$ $42 = 9m + 3n$ Solving simultaneously $M = 3$ and $n = 5$ $A = 3B + n\sqrt{B}$ When $B = 25$ $A = 75 + 25 = 100$	B1 M1 A1	For both values of constants Substitution
		3	
9	Working area = $4.8 \times 3.2 = 15.36 \text{ m}^2$ Mux area = $4.85 \times 3.25 = 15.7625 \text{ m}^2$ Min area = $4.75 \times 3.15 = 14.9625$ Absol error = $\frac{15.7625 - 14.9625}{2}$ $= \frac{0.8}{2}$ $= 0.4$ % error $= \left(\frac{0.4}{15.36} \times 100 \right)$ $= 2.60417$ $= 2.604\%$	M1 B1 A1	For correct areas
		3	
10	x+y=1------(i) Alternative $80x + 60y = 75$ $16x + 12y = 15$ ------(ii) $16x + 16y = 16$ $16x + 12y = 15$ $\hline 4y = 1$ $y = \frac{1}{4}$ OR $\frac{80x + 60y = N}{x + y}$ $x = \frac{3}{4}$ $80x + 60y = 25 \times 75y$ $5x = 15y$	M1 A1	Formation of simultaneous equations Correct Attempt to solve

	$\frac{x}{y} = \frac{15}{5}$ $x:y=3:1 \quad x : y = 3 : 1$	B1	
11	<p>a) $(3-2x)^5 = 3^5 - 5(3^4)(2x) + 10(3^3)(2x)^2 - 10(3^2)(2x)^3 + \dots$ $= 243 - 810x + 1080x^2 - 720x^3 + \dots$</p> <p>b) $(2.98)^5 = (3-0.02)^5$ $2x = 0.02$ $x = 0.01$ $(2.98)^5 = 243 - 810(0.01) + 1080(0.01)^2 - 720(0.01)^3$ $= 243 - 8.1 + 0.108 - 0.00072$ $= 235.00728$ $= 235.007$</p>	M1 A1 B1 A1	Correct substitution
12	$2 \times \frac{22}{7} \times r^2 + 2 \times \frac{22}{7} \times 12 \times r = 836 \text{ cm}^2$ $r^2 + 12r - 133 = 0$ $(r+19)(r-7) = 0$ $= 7 \text{ or } -19$ $r = 7 \text{ cm}$	M1 B1 A1	factorisation substantiated
13	$ox = \frac{5}{3} \begin{pmatrix} 5 \\ 4 \\ -6 \end{pmatrix} + \frac{-2}{3} \begin{pmatrix} 2 \\ -2 \\ 0 \end{pmatrix}$ $\frac{1}{3} \begin{pmatrix} 25 \\ 20 \\ -30 \end{pmatrix} + \frac{1}{3} \begin{pmatrix} -4 \\ 4 \\ 0 \end{pmatrix}$ $\frac{1}{3} \begin{pmatrix} 21 \\ 24 \\ -30 \end{pmatrix} = \begin{pmatrix} 7 \\ 8 \\ -10 \end{pmatrix}$ $x(7, 8, -10)$	M1 B1 A1	Substitution in ratio theorem Column vector obtained coordinates
		3	
		3	

14	$\frac{3(2+3\sqrt{2})+5(2-3\sqrt{2})}{4-18}$ $= \frac{6+9\sqrt{2}+10-15\sqrt{2}}{-14}$ $\frac{16-6\sqrt{2}}{-14}$ $= -\frac{8}{7} + \frac{3}{7}\sqrt{2}$	<p>M₁</p> <p>M₁</p> <p>A₁</p>	<p>Correct Rationalisation</p> <p>Correct simplification</p>
		3	
15	$\frac{dy}{dx} = 6x - 9 \text{ at } x=3$ $= 18 - 9 = 9$ <p>Gradient of normal = $-\frac{1}{9}$</p> <p>When $x = 3, y = 27 - 27 + 1 = 1$</p> $y = \frac{-1}{9}x + c$ $1 = \frac{-1}{9}(3) + c$ $1 + \frac{1}{3} = c \Rightarrow \frac{4}{3}$ $y = \frac{-1}{9}x + \frac{4}{3} \text{ or } 9y + x = 12$	<p>B₁</p> <p>M₁</p> <p>A₁</p>	<p>Gradient</p> <p>Alternation</p> $\frac{y-1}{x-3} = \frac{-1}{9}$ $y-1 = \frac{-1}{9}x + \frac{1}{3}$ $y = \frac{-1}{9}x + \frac{4}{3}$ $y = \frac{-1}{9}x + \frac{4}{3}$
		3	

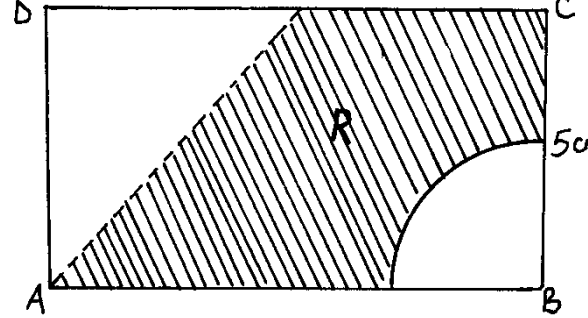
16		<p>B₁</p> <p>B₁</p> <p>B₁ 03</p>	<p>✓ arc constructed</p> <p>Bisecting ∠BAD</p> <p>Shading the region</p>
----	---	---	--

17	SECTION II (50 MKS)		
	<p>(a i) Taxable income per month = $19200 + 12000 + 1300 + 2300$ $= 34800$</p> <p>(ii) $(8400 \div 20)2 = 840$ $(9600 \div 20)3 = 1440$ $(12000 \div 20)4 = 2400$ $(4800 \div 20)5 = 1200$</p> <p>Gross tax = $840 + 1440 + 2400 + 1200 = 5880$</p> <p>Net tax $5880 - 1240 = 4640$</p> <p>b)</p> <p>$230 + 100 + 4000 + 1200 = 5530$ $34800 - 4640 - 5530 =$ 24630</p>	<p>M1 A1</p> <p>M1</p> <p>M1 M1 B1</p> <p>A1</p> <p>M1 M1 A1</p>	<p>First 2 bands</p> <p>Third band Fourth band</p>
		10	

18a	$\begin{pmatrix} 1-3 \\ 01 \end{pmatrix} \begin{pmatrix} xyz \\ 2,4,4 \\ -1-12 \end{pmatrix} = \begin{pmatrix} x_1, y_1, z_1 \\ 5,7,-2 \\ -1,-1,2 \end{pmatrix}$ <p style="margin-left: 40px;"> $X_1(5,-1)y_1(7,-1)z_1(-2,2)$ Xyz & $x_1y_1z_1$ well drawn </p> <p>(b) $\begin{pmatrix} 0-2 \\ 2,0 \end{pmatrix} \begin{pmatrix} 5,7-2 \\ -1,-1,2 \end{pmatrix} = \begin{pmatrix} 2,2,-4 \\ 10,14,-4 \end{pmatrix}$</p> <p style="margin-left: 40px;"> $X_2(2,10)y_2(2,14)z_2(-4-4)$ $X_2y_2z_2$ well drawn </p> <p>(c) $\begin{pmatrix} 0,-2 \\ 2,0 \end{pmatrix} \begin{pmatrix} 1,-3 \\ 0,1 \end{pmatrix} = \begin{pmatrix} 0,-2 \\ 2,-6 \end{pmatrix}$</p> <p>(d) Area of $\Delta x_2y_2z_2$ $=4 \times 15$ $=60\text{cm}^2$</p>	M1 A1 B2 B1 B1 M1 A1 M1 A1																																																									
		10																																																									
19	<table border="1" style="width: 100%; border-collapse: collapse; text-align: center;"> <thead> <tr> <th></th> <th>x</th> <th>f</th> <th>A=1049.5 t=x-A</th> <th>ft</th> <th>t²</th> <th>ft²</th> </tr> </thead> <tbody> <tr> <td>800-899</td> <td>849.5</td> <td>3</td> <td>-200</td> <td>-600</td> <td>40,000</td> <td>120,000</td> </tr> <tr> <td>900-999</td> <td>949.5</td> <td>10</td> <td>-100</td> <td>-1000</td> <td>10,000</td> <td>100,000</td> </tr> <tr> <td>1000-1099</td> <td>1049.5</td> <td>23</td> <td>0</td> <td>0</td> <td>0</td> <td>0</td> </tr> <tr> <td>1100-1199</td> <td>1149.5</td> <td>9</td> <td>100</td> <td>900</td> <td>10,000</td> <td>90,000</td> </tr> <tr> <td>1200-1399</td> <td>1299.5</td> <td>3</td> <td>250</td> <td>750</td> <td>62500</td> <td>187,500</td> </tr> <tr> <td>1400-1599</td> <td>1499.5</td> <td>2</td> <td>450</td> <td>900</td> <td>202,500</td> <td>405,000</td> </tr> <tr> <td></td> <td></td> <td></td> <td></td> <td>Σft =950</td> <td></td> <td>Σft² 902,500</td> </tr> </tbody> </table> <p style="margin-left: 40px;">i) mean $\bar{x} = 1049.5 + \frac{950}{40}$ $= 1073.25$</p> <p style="margin-left: 40px;">ii) $SD = \sqrt{\frac{902500}{40} - \left(\frac{950}{40}\right)^2}$ $= \sqrt{22562.5 - 564.0625}$ $= 148.3187$</p> <p>b) now mean = $1073.25 + 100 = 1173.25$</p>		x	f	A=1049.5 t=x-A	ft	t ²	ft ²	800-899	849.5	3	-200	-600	40,000	120,000	900-999	949.5	10	-100	-1000	10,000	100,000	1000-1099	1049.5	23	0	0	0	0	1100-1199	1149.5	9	100	900	10,000	90,000	1200-1399	1299.5	3	250	750	62500	187,500	1400-1599	1499.5	2	450	900	202,500	405,000					Σft =950		Σft² 902,500	M1 A1 M1 A1 B1	Each column correct B1 (x,t, ft,t ² ,& ft ²)
	x	f	A=1049.5 t=x-A	ft	t ²	ft ²																																																					
800-899	849.5	3	-200	-600	40,000	120,000																																																					
900-999	949.5	10	-100	-1000	10,000	100,000																																																					
1000-1099	1049.5	23	0	0	0	0																																																					
1100-1199	1149.5	9	100	900	10,000	90,000																																																					
1200-1399	1299.5	3	250	750	62500	187,500																																																					
1400-1599	1499.5	2	450	900	202,500	405,000																																																					
				Σft =950		Σft² 902,500																																																					

Download this and other FREE materials from <https://teacher.co.ke/notes>

20	<p>(a) $80x + 20y \geq 1000$ $y \leq 2x$ $x + y < 30$ $y > 10$</p> <p>(b) $80x + 20y \geq 1000$ drawn & shaded $y \leq 2x$ draw & shaded $x + y < 30$ & $y > 10$ drawn & shaded vly</p> <p>C) $1800x + 1000y = A$ At (10,15) $\therefore A = 37000$ $9x + 5y = 185$ Max at (18,11) Max amount = $(18 \times 1800) + (11 \times 1000)$ =sh 43,400</p>	<p>B1 B1 B1 B1</p> <p>L1 L1 L1</p> <p>B1 M1 A1</p>	

Download this and other FREE materials from <https://teacher.co.ke/notes>

		10	
21	<p>i)</p> $PQ = \sqrt{12^2 + 10^2} = \sqrt{244} \text{ cm}$ $QS = \sqrt{(\sqrt{244})^2 + 12^2}$ $= 19.70 \text{ cm}$ <p>ii)</p> $SR = \sqrt{12^2 + 10^2}$ $= 15.62 \text{ CM}$ $12^2 = 19.7^2 + 15.62^2 - 2 \times 19.7 \times 15.62 \cos x$ $\cos x = 0.79306$ $x = 37.53^\circ$ <p>iii) volume</p> $= \left(\frac{1}{2} \times 10 \times 12 \right) \times 12$ $= 720 \text{ cm}^3$ <p>Mass</p>	<p>M1 M1 A1</p> <p>M1 A1</p> <p>M1 A1 B1</p>	<p>Finding SR</p> <p>SR obtained</p>

		720×15 10800 g 10.80 kg	M1 A1																															
			10																															
22	<table border="1"> <tr> <td>X</td> <td>-5</td> <td>-4</td> <td>-3</td> <td>-2</td> <td>-1</td> </tr> <tr> <td>X^3</td> <td></td> <td></td> <td>-27</td> <td></td> <td></td> </tr> <tr> <td>$6X^2$</td> <td>150</td> <td></td> <td></td> <td>24</td> <td></td> </tr> <tr> <td>$8X$</td> <td></td> <td>-32</td> <td></td> <td></td> <td>-8</td> </tr> <tr> <td>Y</td> <td>-15</td> <td>0</td> <td></td> <td>-3</td> <td>-3</td> </tr> </table>	X	-5	-4	-3	-2	-1	X^3			-27			$6X^2$	150			24		$8X$		-32			-8	Y	-15	0		-3	-3		B ₂	All values correct B1 for any 4 correct
X	-5	-4	-3	-2	-1																													
X^3			-27																															
$6X^2$	150			24																														
$8X$		-32			-8																													
Y	-15	0		-3	-3																													
			S ₁ P ₁ C ₁	Correct scale plotting smooth curve																														
			B ₁	Y=x-1 obtained																														
			B ₁	Line x-1 drawn																														
			B ₁	Values (-4.5,-1.4 and -0.2)																														
			B ₁	for $-3.5 < x < -2.4$																														
			B ₁	For $0.3 < x < 1$																														
23	<p>(a) (PTS = 52° (alt. seg. theorem) b</p>		B1 B1 B1 B1 B1 B1 B1 B1 B1 B1	Angle obtained and reason given																														

	(b) $\angle RTQ = 38^\circ$ (Ls in str line PTQ) (c) $\angle TSR = 38^\circ$ (Alt seg thorem) (d) $\angle TQR = 14^\circ$ (Ls in Δ) (e) $\angle PSQ = 102^\circ$ (Ls in Δ)		
		10	
24.	(a) $\frac{400}{10000}$ $=0.04$ (b) (i) scores 7,8,9, $\frac{3 \times 400}{10,000}$ $=0.12$ (ii) $\frac{6400}{10000}$ $=0.64$ © (i) scores 9,9 $\frac{400}{10000} \times \frac{400}{10000}$ $=0.0016$ (ii) 9,9,8, $3 \left(\frac{400}{10000} \right) =$ 0.00064	M1 A1 M1 A1 M1 A1 M1 A1 M1 A1	