

**SECTION A (25 MARKS)**

Answer *all* the questions in this section in the spaces provided.

1. **Figure 1** shows the vernier scale of a vernier calliper.



**Figure 1**

On the figure, include the main scale so that the vernier calliper shows a reading of 3.15cm.

(2 marks)

2. Explain why weight of an object is a vector quantity.

(1 mark)

.....

.....

.....

.....

3. **Figure 2** shows the shape of a bimetallic strip made of metals **A** and **B** when heated.

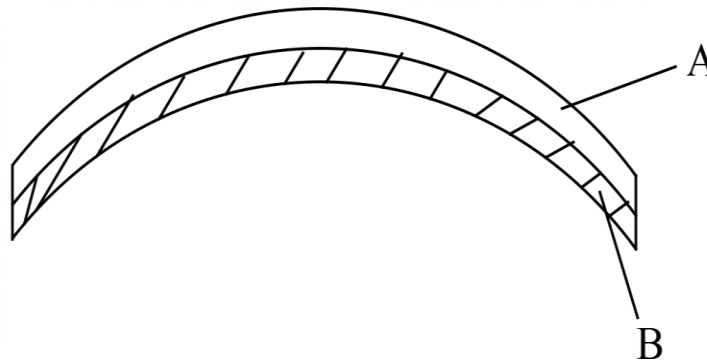

**Figure 2**

State the reason why the strip appears as shown.

(1 mark)

.....

.....

.....

4. It is observed that in order to balance a sea-saw, the heavier child sits closer to the pivot. State the reason for this observation. (2 marks)

.....

.....

.....

5. Explain **one** way in which a person maintains stability when carrying a bucket of water in one hand. (1 mark)

.....

.....

6. **Figure 3** shows a simple hand sanitizer dispenser.

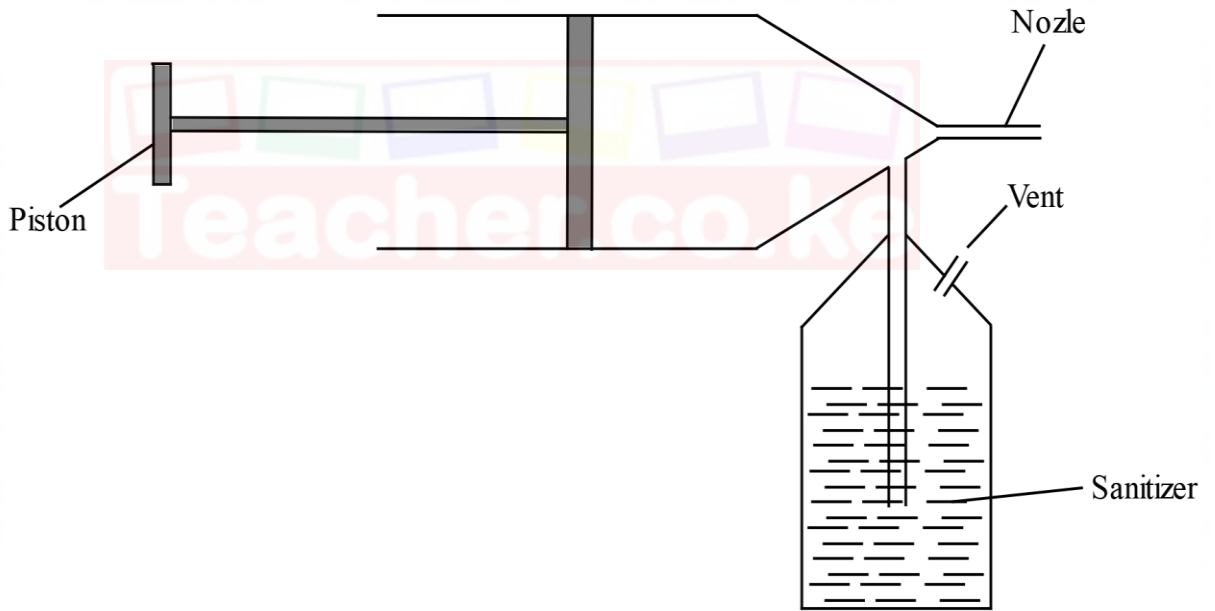

**Figure 3**

Explain how it works. (3 marks)

.....

.....

.....

.....

7. **Figure 4** shows a marble that was set into oscillations when released in a bowl.

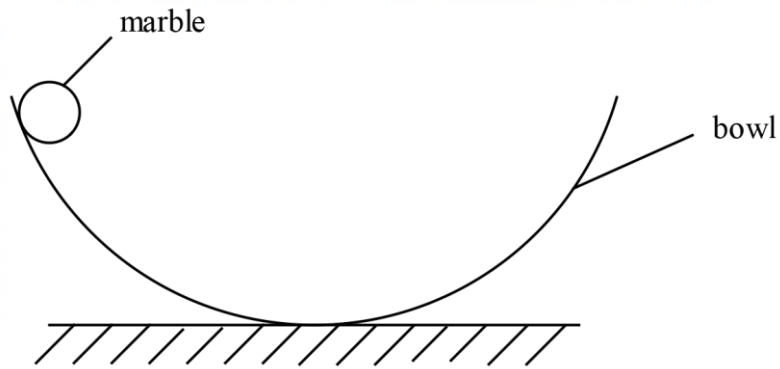

**Figure 4**

On the axes provided, sketch the velocity-time graph for the motion of the marble in one complete oscillation. (3 marks)

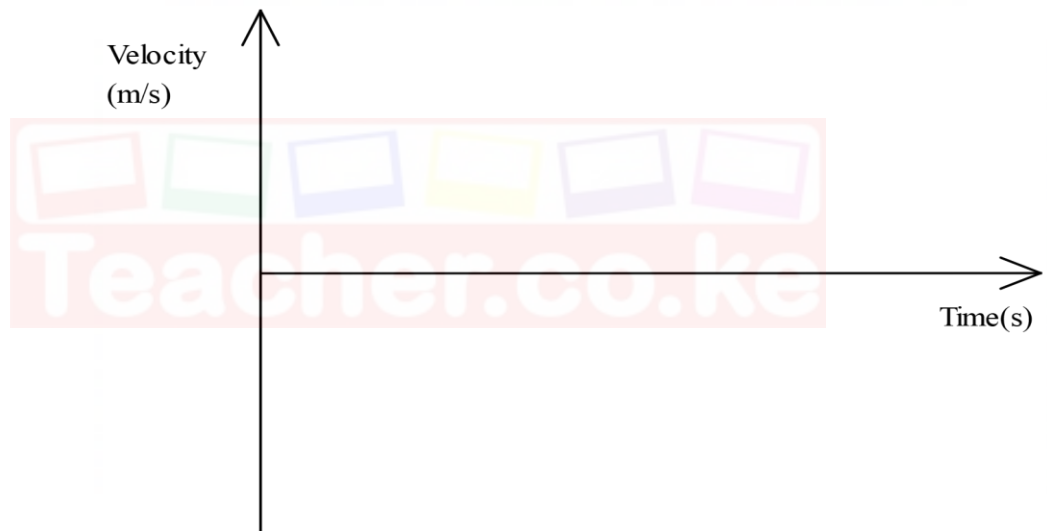

8. State the meaning of the term *viscosity* as used in fluids. (1 mark)

(1 mark)

.....

.....

.....

9. A machine raises a mass of 20 kg through a distance of 0.2 m when an effort of 100 N is moved through a distance of 0.32 m. determine the velocity ratio of the machine. (2 marks)

(2 marks)

.....

.....

.....

.....

10. A gas bubble is released at the bottom of a pond containing water. It is observed that as the bubble rises to the water surface, it expands. Explain this observation. (2 marks)

.....  
.....  
.....  
.....

11. A stone of mass 200 g is tied at the end of a string 1 m long is whirled in a horizontal circle at an angular velocity of 10 radians per second. Determine the centripetal force acting on the stone.

(3 marks)

.....  
.....  
.....  
.....  
.....  
.....

12. An object is released into a eureka can full of water. It is observed that the weight of the displaced water is equal the weight of the object. Explain this observation. (2 marks)

.....  
.....  
.....

13. A student observed that smoke particles in a smoke cell move randomly. State what:

(a) causes this motion; (1 mark)

.....  
.....  
.....

(b) happens to the motion of the particles if the temperature in the cell is increased.

(1 mark)

.....  
.....  
.....

**SECTION B (55 marks)**

Answer **all** the questions in this section in the spaces provided.

14. (a) (i) State the meaning of the term *relative density*. (1 mark)

.....  
.....  
.....  
.....

- (ii) State **two** areas of application of relative density in daily life. (2 marks)

.....  
.....  
.....  
.....

- (b) A student blew air into a balloon, tied it up and released it into the air. It floated for some time but slowly descended to the ground and settled.

- (i) Explain why the balloon settled on the ground. (2 marks)

.....  
.....  
.....  
.....

- (ii) State **two** ways in which the balloon could be made to keep floating in the air.

(2marks)

- (c) A hollow metallic cube of volume  $1000 \text{ cm}^3$  is submerged in a liquid of density  $1100 \text{ kgm}^{-3}$ . Determine the upthrust acting on it. (take  $g$  as  $10 \text{ Nkg}^{-1}$ ) (3 marks)

.....  
.....  
.....  
.....  
.....  
.....

15. (a) During an experiment to verify a certain law, a student was provided with some masses, a spring and a metre rule.

(i) State the law the student wanted to verify. (1 mark)

.....  
.....  
.....

(ii) State **one** other apparatus the student needed in order to carry out the experiment. (1 mark)

.....  
.....  
.....

(iii) Explain how the measurements taken during the experiment are used to verify the law in part (i) above. (3 marks)

.....  
.....  
.....  
.....

(b) A load of 0.04 N causes an extension of 0.4 cm on a certain spring. Determine the load that will cause an extension of 0.6 cm on the same spring. (3 marks)

.....  
.....  
.....  
.....  
.....  
.....  
.....

- (c) A student was provided with a piece of wire and asked to make a spring. After coiling the wire on a rod, the spring appeared as shown in **Figure 5**.

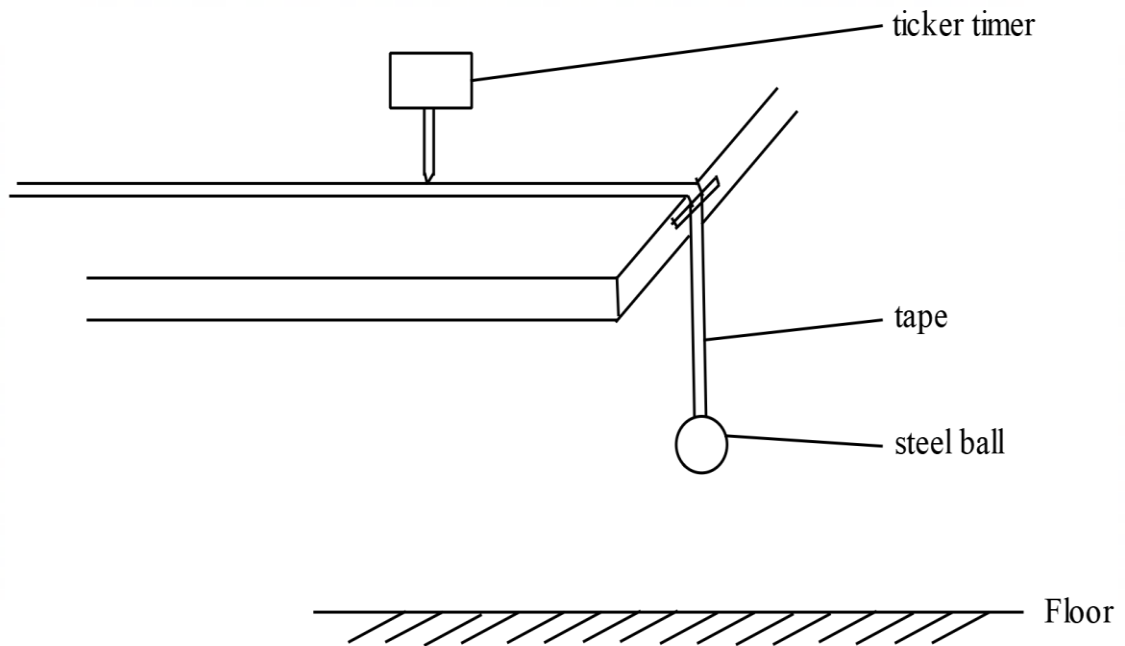

**Figure 5**

State **two** ways in which the student can modify the spring to make it stiffer.

(2 marks)

16. (a) **Figure 6** shows a setup that may be used to determine acceleration due to gravity.



**Figure 6**

Describe how the set up may be used to determine the acceleration due to gravity. (4 marks)

.....

.....

.....

.....

.....

.....

.....

.....

.....

.....

- (b) A stone of mass 0.02 kg tied at the end of a spring is whirled in a vertical circle of radius 1.0 m. Determine the minimum velocity required for the stone to maintain circular motion. (*acceleration due to gravity is  $10 \text{ ms}^{-2}$* ). (4 marks)

.....

.....

.....

.....

.....

.....

.....

.....

.....

.....

- (c) State **two** applications of centripetal force. (2 marks)

.....

.....

.....

.....

17. (a) It is observed that when salt is sprinkled onto the surface of ice at  $-2 \text{ }^\circ\text{C}$ , the ice melts. Explain this observation. (2 marks)

.....

.....

.....

.....

- (b) State **two** factors that determine the pressure exerted by solids. (2 marks)

.....  
.....

- (c) (i) A person mixed 2 kg of hot water at  $70\text{ }^{\circ}\text{C}$  with 3 kg of cold water at  $22\text{ }^{\circ}\text{C}$  for bathing. Given that the specific heat capacity of water is  $4200\text{ JkgK}^{-1}$ , determine the final temperature of the mixture, assuming there was no heat loss. (3 marks)

.....  
.....  
.....  
.....  
.....  
.....

- (ii) State **two** possible factors that can lead to heat loss in (i). (2 marks)

.....  
.....  
.....  
.....

- (d) Some water at  $60\text{ }^{\circ}\text{C}$  was heated until it started to boil after time  $t$  seconds.

- (i) On the axes provided, sketch a graph of temperature against time for the water till it boiled. (2 marks)

Temperature  $^{\circ}\text{C}$

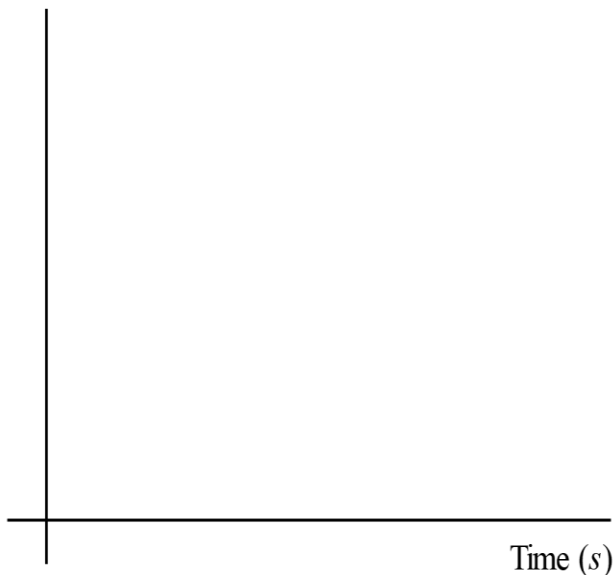

(ii) Explain the shape of the graph in (i). (2 marks)

.....

.....

.....

.....

18. (a) Explain why the walls of a dam are thicker at the bottom than at the top. (3 marks)

.....

.....

.....

.....

(b) Figure 7 shows a simple hydraulic lift system.

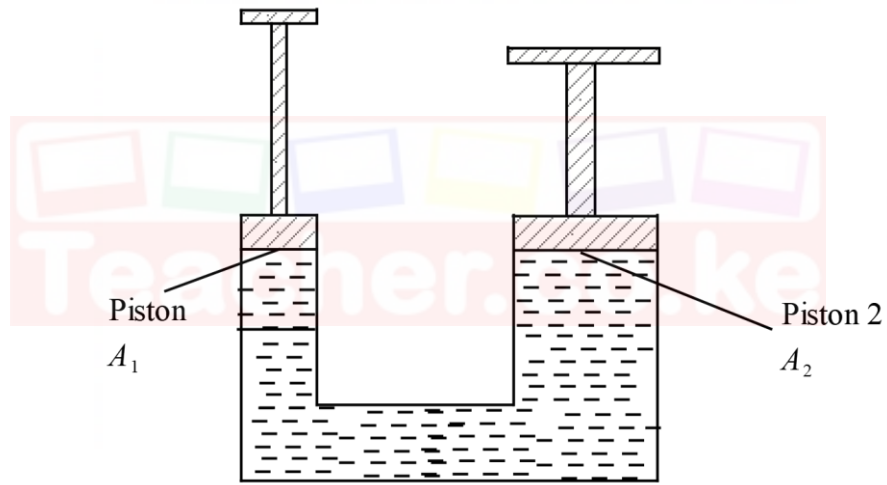

Figure 7

(i) Given that the areas  $A_1$  and  $A_2$  are  $0.2 \text{ m}^2$  and  $4 \text{ m}^2$  respectively, determine the maximum load that can be lifted at piston 2, when a force of  $200 \text{ N}$  is applied at piston 1. (3 marks)

.....

.....

.....

.....

.....

(ii) State **two** reasons why water is not a suitable liquid for use in this system. (2 marks)

.....  
.....  
.....  
.....

(c) **Figure 8** shows a pair of scissors.

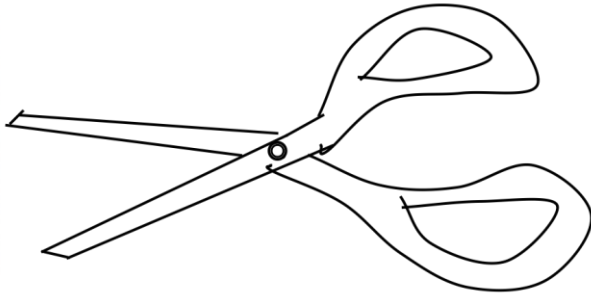

**Figure 8**

(i) On the diagram, label the load, effort and fulcrum. (1 mark)

(ii) Explain how the velocity ratio of the given pair of scissors may be reduced. (2 marks)

.....  
.....  
.....  
.....

(iii) State the reason why it is important to minimize the velocity ratio. (1 mark)

.....  
.....  
.....

**THIS IS THE LAST PRINTED PAGE**