

THE KENYA NATIONAL EXAMINATIONS COUNCIL
Kenya Certificate of Secondary Education



232/3

PHYSICS (Practical)

Paper 3

Nov. 2023 – 2½ hours

Serial No.
28818479

Name: Index Number:

Candidate's signature: Date:

Instructions to candidates

- (a) Write your name and index number in the spaces provided above.
- (b) Sign and write the date of examination in the spaces provided above.
- (c) Answer all the questions in the spaces provided in the question paper.
- (d) You are supposed to spend the first 15 minutes of the 2½ hours allowed for this paper reading the whole paper carefully before commencing your work.
- (e) Marks are given for a clear record of the observations actually made, their suitability, accuracy and the use made of them.
- (f) Candidates are advised to record their observations as soon as they are made.
- (g) Non-programmable silent electronic calculators may be used.
- (h) This paper consists of 11 printed pages.
- (i) **Candidates should check the question paper to ascertain that all the pages are printed as indicated and that no questions are missing.**
- (j) **Candidates should answer the questions in English.**



For Examiner's Use Only

Question 1

	d	g	h	i
Maximum Score	8	5	3	4
Candidate's Score				

Total

--

Question 2

	a	b	c	d	f	g(ii)	g(iii)
Maximum Score	1	2	4	5	3	4	1
Candidate's Score							

Total

--

Grand Total

--



Turn over



Question 1

You are provided with the following:

- a strip of manila paper marked with an equal division scale on one end.
- a plane mirror
- a biconvex lens
- two pieces of wooden blocks
- a stand, boss and clamp
- some glycerine in a beaker
- a dropper
- a half metre rule

Proceed as follows:



- Place the mirror on a horizontal surface and place the lens at the center of the mirror.
- Clamp the wooden blocks so that they hold the strip of manilla with the millimetre scale facing upwards at a height h above the center of the lens. Let h initially be about 300 mm (30 cm). (See Figure 1).

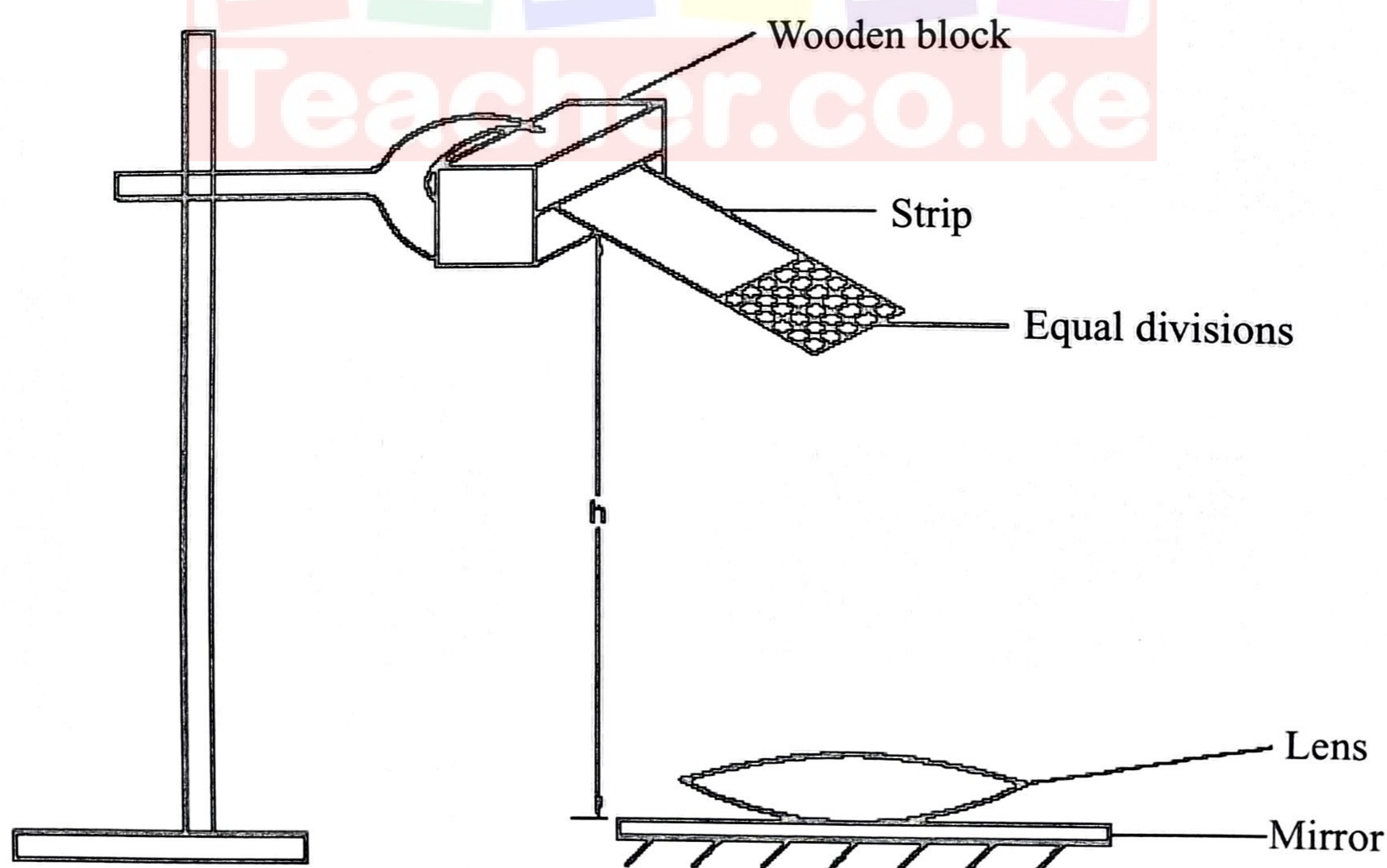

Figure 1

Kenya Certificate of Secondary Education, 2023
232/3

317149

- (c) With the eye vertically above the lens, adjust the position of the mirror and lens so that you can see the image of the strip in the central region of the lens.



Using the divisions on the scale on the top side of the strip, determine the width p of the image when the object (strip) is 300 mm above the lens. (see figure 2)

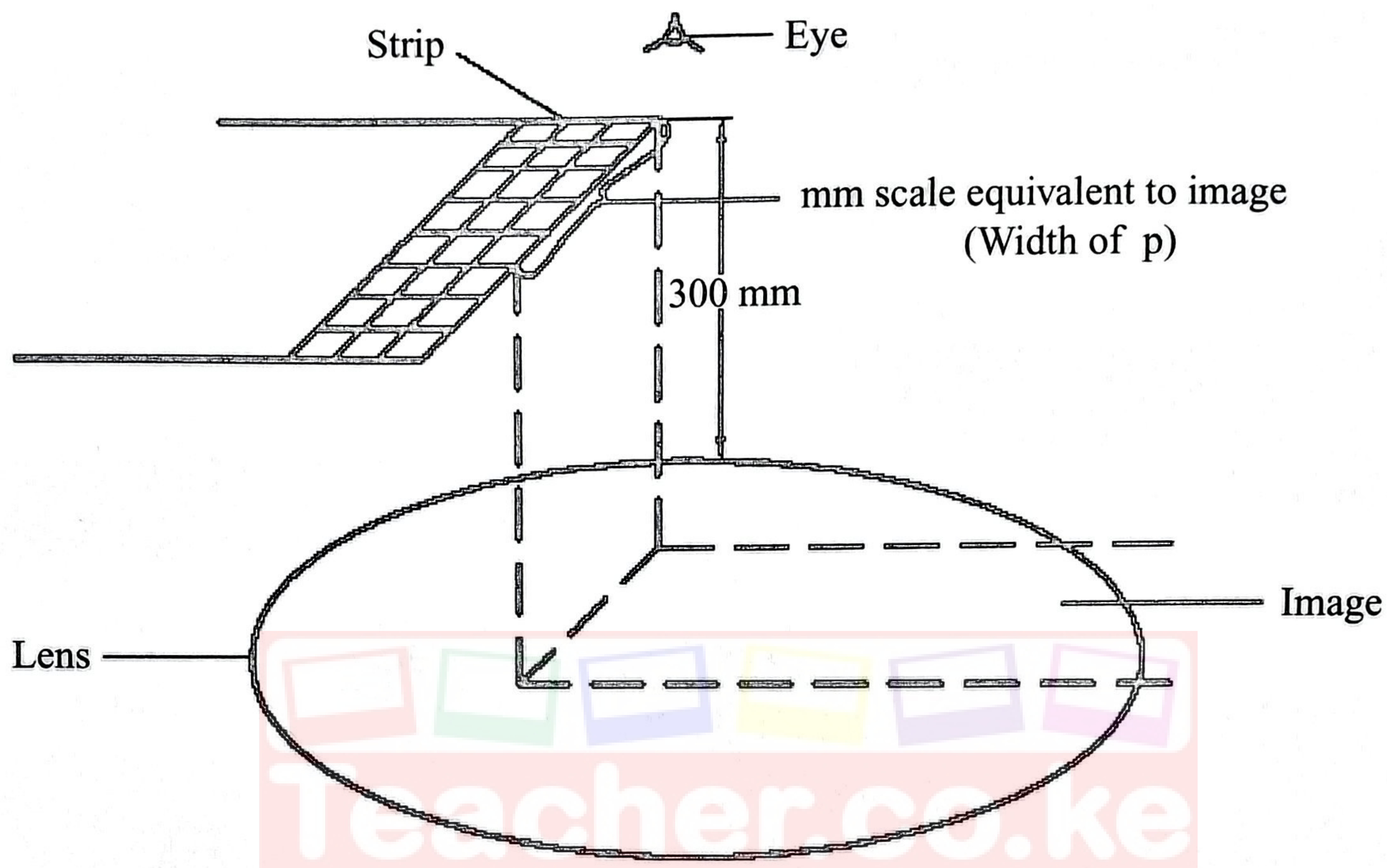

Figure 2

p (width of image) = divisions

- (d) Repeat (c) to obtain p for other values of h shown in Table 1. Record the results in Table 1.



(Hint: When the image is larger than the object, turn the strip upside down so that the scale faces downwards. In this case the width of the image = $\frac{100}{n}$ where n is the number of divisions on the image corresponding to the full width of the object). See figure 3

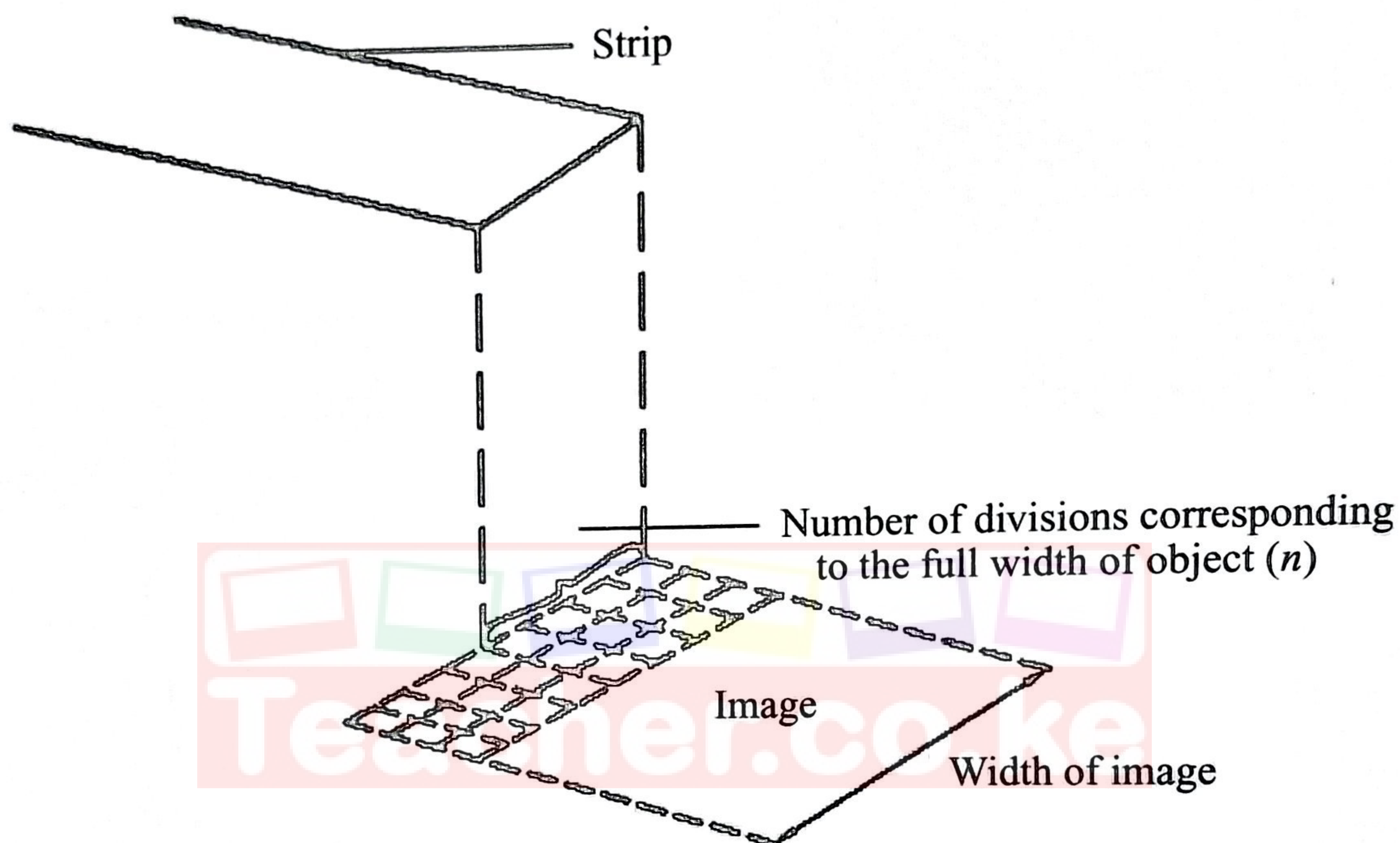

Figure 3

- (e) Remove the lens. Put 8 drops of glycerine in the center of the mirror. Replace the lens on top of the glycerine.
- (f) Repeat (c) to obtain values of the width q for the corresponding values of h in Table 1, (upto $h = 180 \text{ mm}$). Complete Table 1.
- (g) On the grid provided, plot a graph of p (y axis) against h . (5 marks)
- (h) Use the same axes as in (g) to plot a graph of q (y axis) against h . (3 marks)

Table 1

h (mm)	300	280	250	230	200	180	150	130
p (division)								
q (division)								

(8 marks)

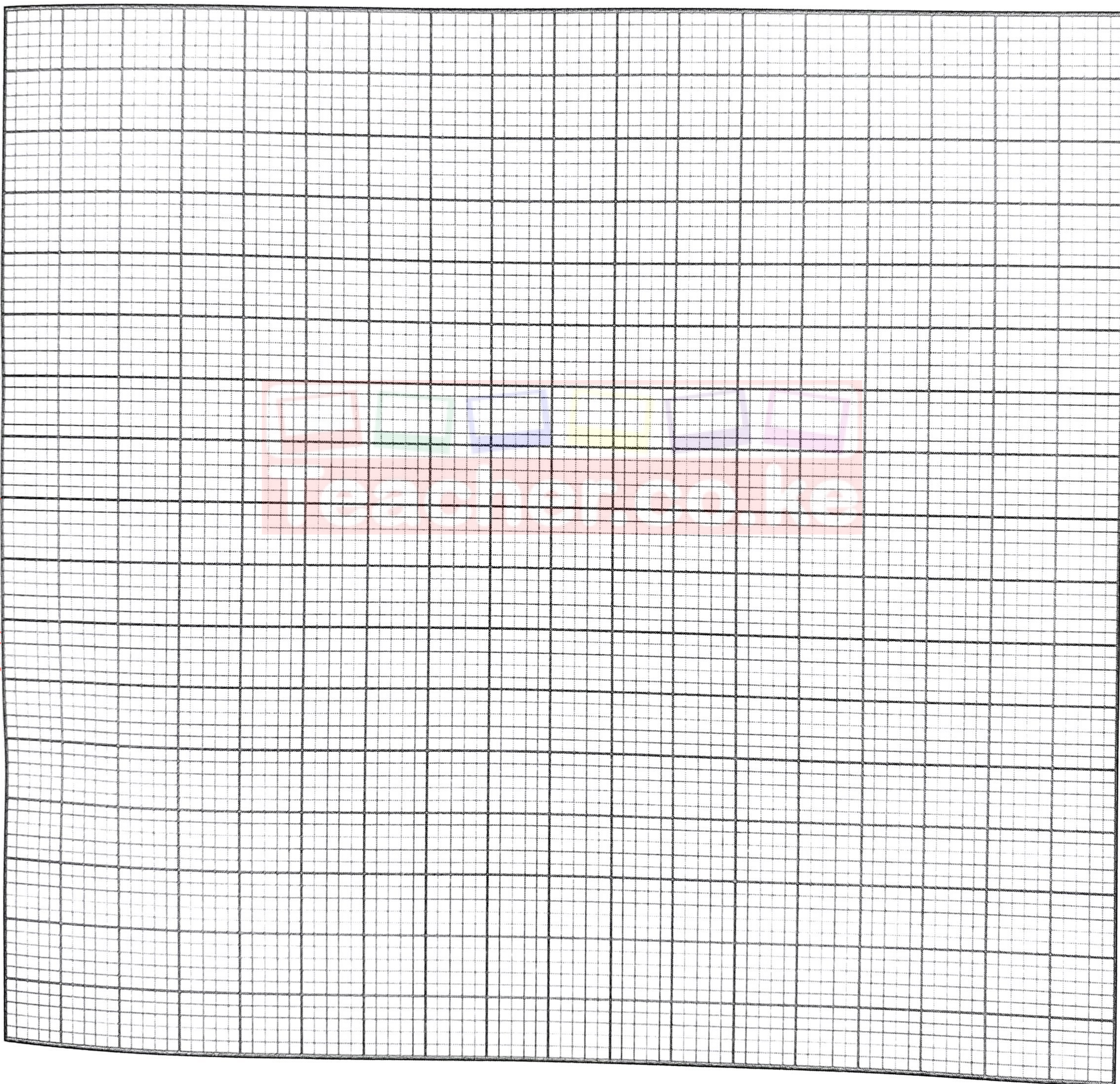

Download this and other FREE materials from <https://teacher.co.ke/notes>



(i) From the graphs determine the:

(i) values of h in each case when the image size is 10 divisions.

$h_p = \dots\dots\dots$

(1 mark)

$h_q = \dots\dots\dots$

(1 mark)

(Where h_p is the value of h for p and h_q is the value of h for q when the width of the image is 10 divisions).



(ii) the refractive index η of glycerine given that: $\eta = 2 - \frac{h_p}{h_q}$

(2 marks)

.....
.....
.....
.....
.....



Question 2

You are provided with the following:

- Two dry cells
- A galvanometer
- Two cell holders
- Two switches
- A voltmeter
- An ammeter
- A jockey
- Nine connecting wires
- A resistance wire mounted on a millimetre scale labelled A B.
- A resistance wire mounted on a millimetre scale labelled P Q.
- A component X
- A thermometer
- Two beakers one containing water
- One carbon resistor labelled $10\ \Omega$
- A source of hot water (*to be shared*)

Proceed as follows:

PART A

(a) Set up the circuit as shown in Figure 4.

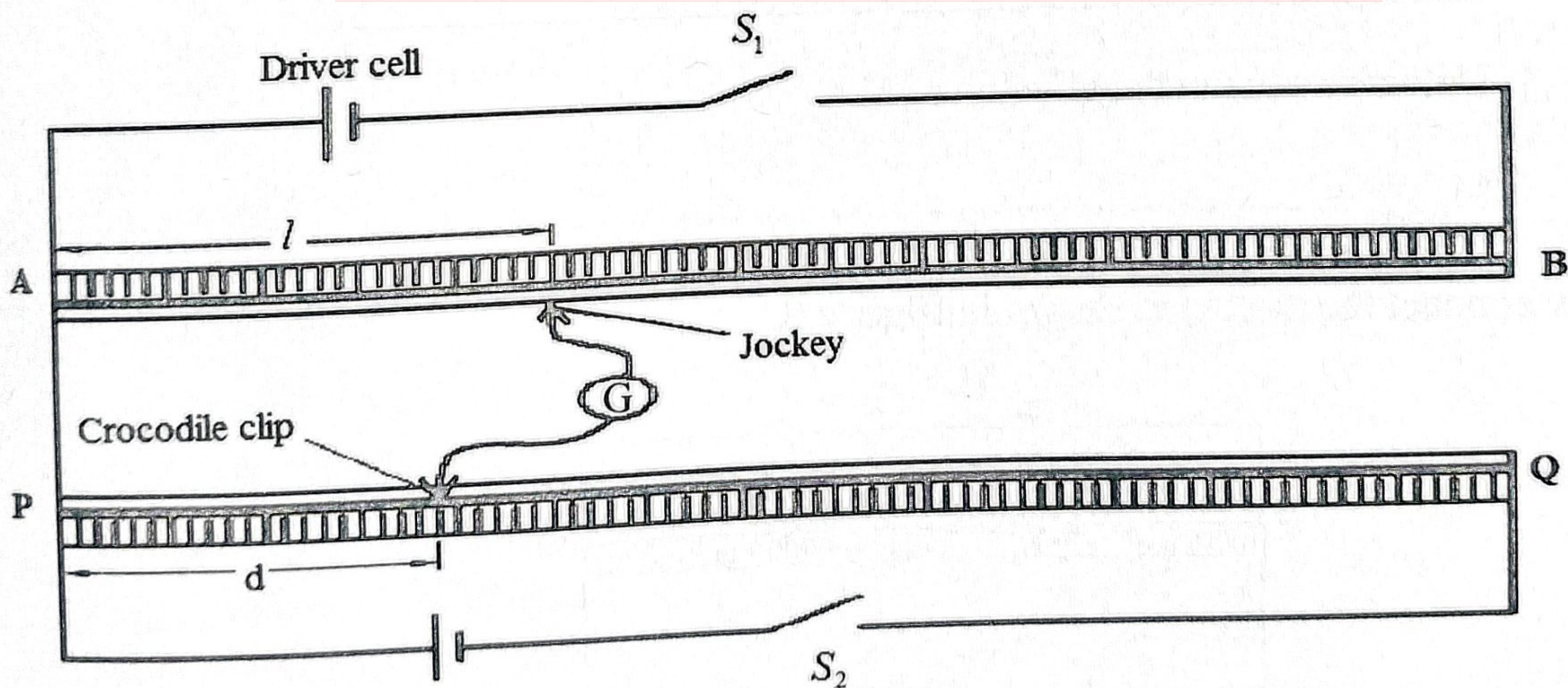

Figure 4



With S_1 and S_2 open, connect a voltmeter across the driver cell and record the voltmeter reading E .

$E = \dots\dots\dots$ volts

(1 mark)

- (b) (i) Adjust distance d to 10 cm from P. Move the jockey along AB to obtain the balance length l . (*No deflection on the galvanometer*)

$l = \dots\dots\dots$ cm.

(1 mark)

- (ii) Determine constant m given that $m = \frac{l}{d}$

(1 mark)

.....

- (c) (i) Repeat (b) for the other values of d in Table 2 and complete the Table 2.

Table 2

$d(\text{cm})$	10	30	50
l (cm)			
$m = \frac{l}{d}$			

(2 marks)

- (ii) Determine the average value of M

$M_{\text{average}} = \dots\dots\dots$

(2 marks)

- (d) Now connect the circuit as shown in Figure 5.

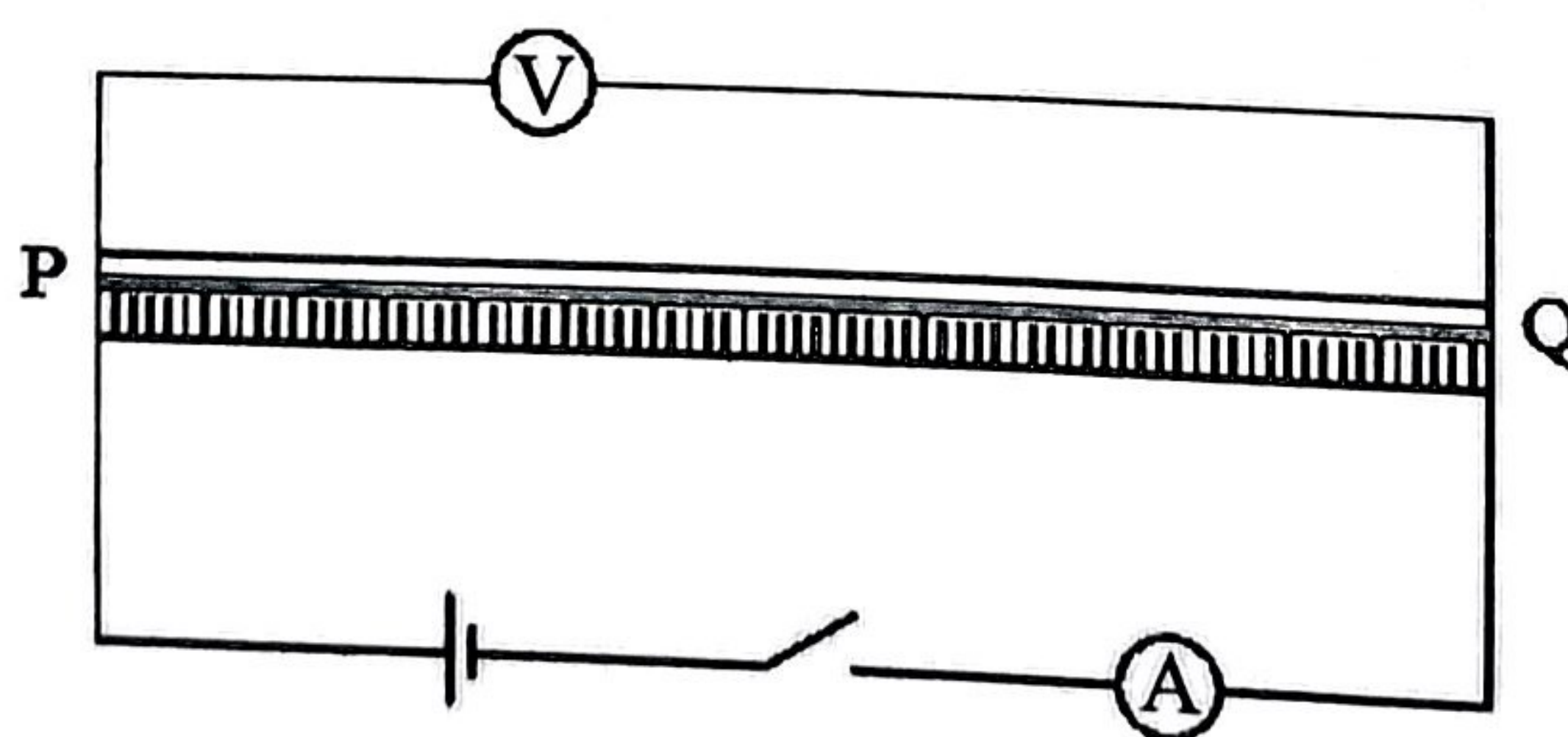

Figure 5



(i) Measure and record the current I through the circuit and the potential difference (p.d.) across PQ .

$I = \dots\dots\dots$ (1 mark)

$V = \dots\dots\dots$ (1 mark)

(ii) Determine the resistance R of the wire. (1 mark)

.....
.....
.....

(iii) Determine constant K given that: $\frac{E}{KI} = R$ (2 marks)

.....
.....
.....
.....
.....



Download this and other FREE materials from <https://teacher.co.ke/notes>

PART B

- (e) Connect the circuit as shown in Figure 6. Add cold water to the beaker until component X is just covered.

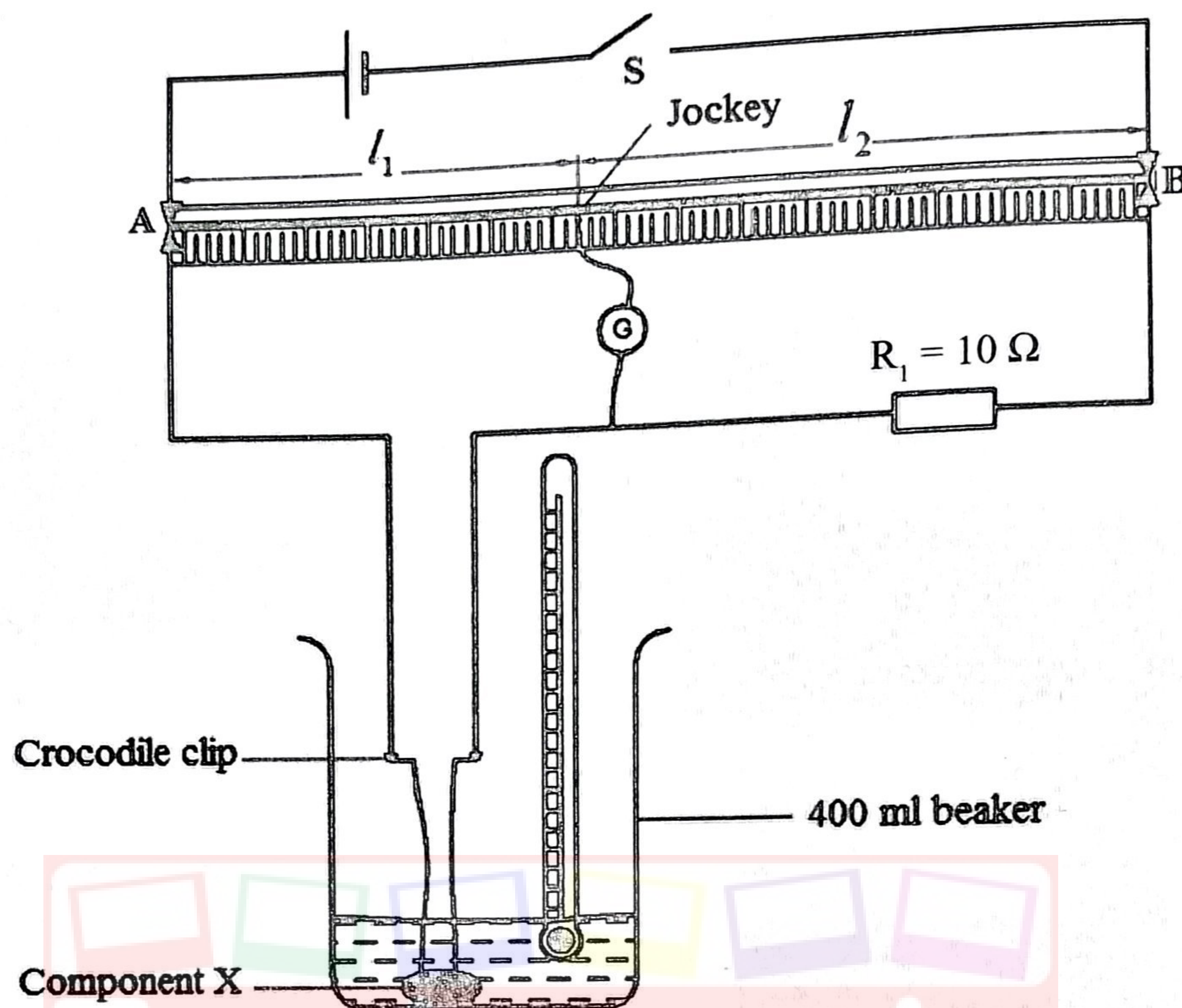

Figure 6

- (f) (i) Record the initial temperature of the water in the beaker θ_o

$$\theta_o = \dots\dots\dots^\circ\text{C}$$

(1 mark)

Close the switch and adjust the position of the jockey on wire AB until there is balance. (No deflection on the galvanometer)

- (ii) Record the balance lengths l_1 and l_2

$$l_1 = \dots\dots\dots$$

$$l_2 = \dots\dots\dots$$

(1 mark)

Open the switch.



(iii) Determine the initial resistance R_o of the component X given that: $R_o = 10 \frac{l_1}{l_2}$ (1 mark)

.....
.....
.....



(g) Raise the temperature of the water covering component X by adding in little amounts of the hot water provided and stirring continuously using the thermometer.

(It may be necessary to pour out some water in order to add more hot water)

(i) Repeat (f) for the values of temperature (θ) shown in Table 3.

(ii) For each of the temperatures in Table 3, determine the constant K , and Complete Table 3

Table 3

Temperature θ °C	l_1 (cm)	l_2 (cm)	$R = 10 \frac{l_1}{l_2}$	$K = \frac{\log\left(\frac{R_o}{R}\right)}{0.4(\theta - \theta_o)}$
40				
50				

(4 marks)

(iii) Determine the average value of K . (1 mark)

.....
.....

THIS IS THE LAST PRINTED PAGE.

