

2024

COMPUTER STUDIES

COMPREHENSIVE NOTES

GRADE 8

JUNIOR SCHOOL

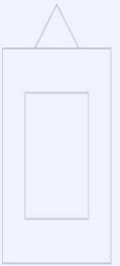
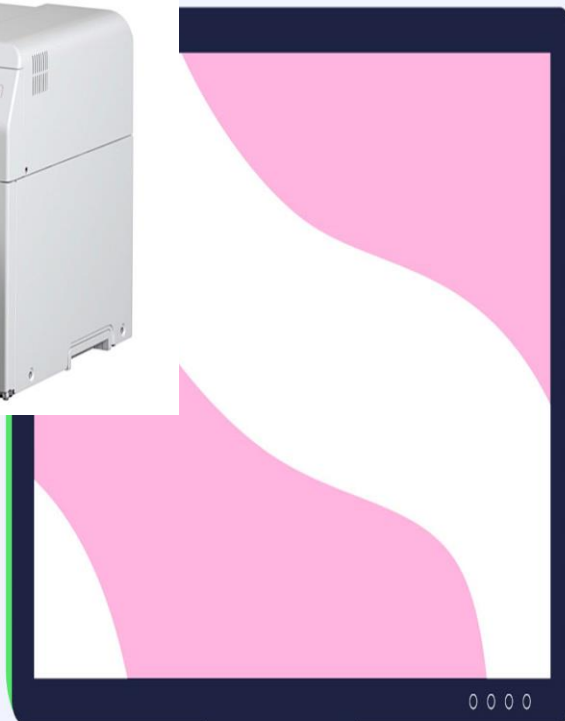

Oscar Mwangi
[Type the company name]
1/1/2024



FOUNDATIONS IN COMPUTER SCIENCE

THE COMPUTER



Please Watch

<https://www.youtube.com/watch?v=mLgTnkW558w>

The basic parts of a desktop computer are the

- **computer case,**
- **monitor,**
- **keyboard,**
- **mouse, and**
- **Power cord.**

Each part plays an **important role** whenever you use a computer.



Computer case

The **computer case** is the metal and plastic box that **contains the main components** of the computer, including the

- Motherboard,
- Central processing unit (CPU), and
- Power supply.

The front of the case usually has an **On/Off button** and one or more **optical drives**.

- Computer cases come in different shapes and sizes.
- A **desktop case** lies flat on a desk, and the monitor usually sits on top of it. A **tower case** is tall and sits next to the monitor or on the floor.
- **All-in-one** computers come with the internal components built into the monitor, which eliminates the need for a separate case.

Monitor



The **monitor** works with a **video card**, located inside the computer case, to display images and text on the screen. Most monitors have **control buttons** that allow you to change your monitor's display settings, and some monitors also have built-in speakers.

- ✓ Newer monitors usually have **LCD** (liquid crystal display) or **LED** (light-emitting diode) displays. These can be made very thin, and they are often called **flat-panel displays**.
- ✓ Older monitors use **CRT** (cathode ray tube) displays. CRT monitors are much larger and heavier, and they take up more desk space.

Keyboard

The **keyboard** is one of the main ways to communicate with a computer. There are many different types of keyboards, but most are **very similar** and allow you to accomplish the same basic tasks.



Mouse



The **mouse** is another important tool for communicating with computers. Commonly known as a **pointing device**, it lets you **point** to objects on the screen, **click** on them, and **move** them.

- ✓ There are two main mouse types: **optical and mechanical**.
- ✓ The **optical** mouse uses an electronic eye to detect movement and is easier to clean.
- ✓ The **mechanical mouse** uses a rolling ball to detect movement and requires regular cleaning to work properly.

Mouse alternatives

There are other devices that can do the same thing as a mouse. Many people find them easier to use, and they also require less desk space than a traditional mouse. The most common mouse alternatives are below.

- ✓ **Trackball:** A trackball has a ball that can rotate freely. Instead of moving the device like a mouse, you can roll the ball with your thumb to move the pointer.
- ✓ **Touchpad:** A touchpad—also called a **track pad**—is a touch-sensitive pad that lets you control the pointer by making a drawing motion with your finger. Touchpads are common on laptop computers.



Assembling and disassembling computer case

Part1: How to assemble a CPU step by step

This part is all about CPU assembling. Specifically, you have to be very careful with this process.

Following are the steps to assemble CPU:

1. Take Inventory
2. Make space and time
3. Prepare your CPU case
4. Install motherboard
5. Install the processor
6. Install the processor heat sink
7. Install the RAM
8. Install SMPS
9. Install the HDD
10. Install CD/DVD drive
11. Connect Expansion cards
12. Install SYS/Rear cooling fan
13. Bus cable connection
14. Power Cable connection
15. Front Panel connector connection

1. Take Inventory:

Before you start, take inventory of your parts. Make sure you have the following components and tools with you.

1. Case/ Tower/Cabinet
2. Motherboard
3. Processor
4. Heat Sink and CPU Fan
5. SMPS
6. Hard disk drive
7. CD/ DVD drive
8. RAM
9. CMOS Battery
10. A good screwdriver sets

2. Make Space, Make Time:

Building a PC takes space. You can use your dining room table to build your PC. So, make sure you have plenty of working space and a few hours to proceed with minimal interruption. You must work on a flat, stable tabletop surface or bare floor, where you have room to lay out all of the items, to begin with, assemble.

3. Prepare your CPU cabinet:

Now it is time to prepare the case. Remove the case cover from the CPU cabinet.

You need to check Screw brass standoffs are perfectly placed or not. If it is not in a proper position, in that case, you need to position them accurately. (always check the manual and follow their instructions)

4. Install the motherboard:

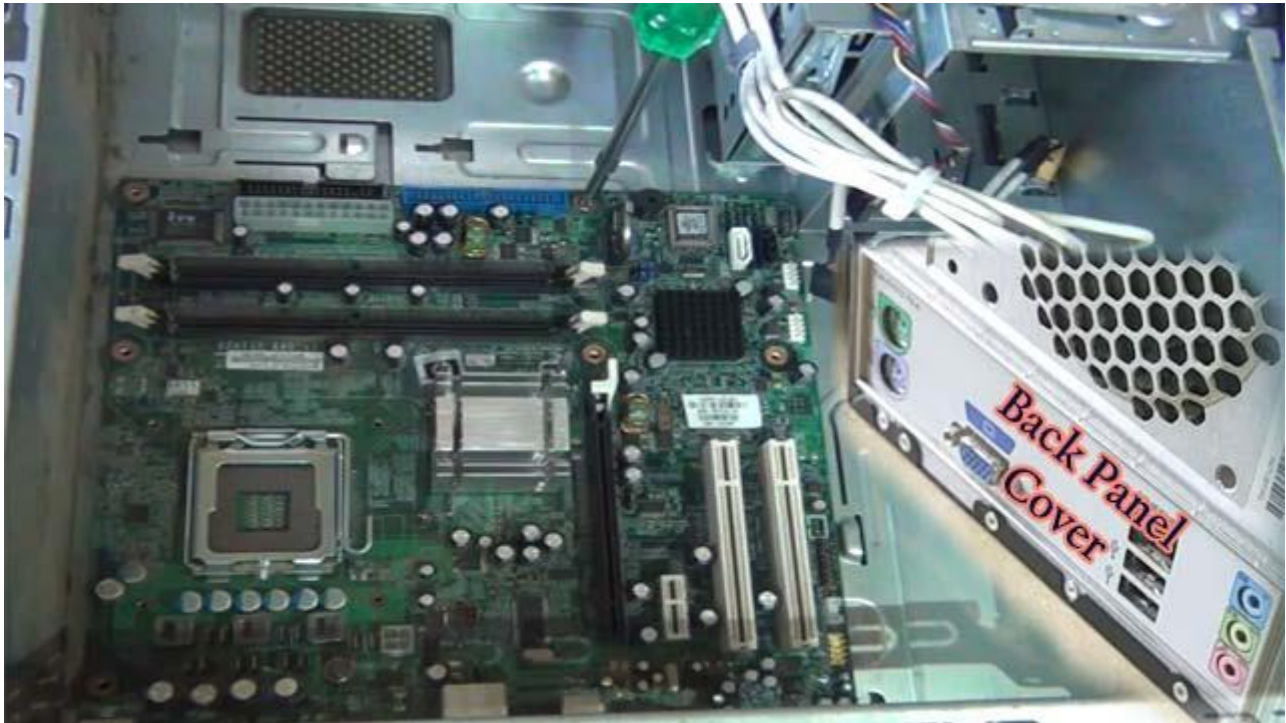

Fig: motherboard and Back panel cover

You must take great care, especially when installing the motherboard. First, remove the motherboard of its packaging and put it on top of the antistatic bag it came in. Remember, you always want to safeguard your components from potentially hazardous static electricity.

1. You need to secure the motherboard onto the PC case/chassis and inspect carefully for any visible defects.
2. Next, review the motherboard handbook, to make sure you are familiar with the motherboard layout and understand which socket is which. Manuals are immensely helpful, usually easy to read, and include illustrations instructions.
3. Check the layout of the sockets on the motherboard. And confirm that the ports on your motherboard's back panel match the holes on the case's Input/output (I/O) shield installed in your case. If it is necessary, then remove the old I/O shield by

tapping it firmly a few times with the thicker end of a screwdriver. And then replace it with the shield that came with the new motherboard.

4. You need carefully position the motherboard on top of the brass standoffs. After that line up all the holes, use the screws that accompanied the case to fasten down the motherboard.
5. Don't forget to place the CMOS in the proper position.

5. Install the processor (CPU):



Fig: CPU placement

1. Use the unlocking mechanism to open the CPU socket which is, usually a lever.
2. Carefully line up the pins and place the chip in its socket; it will fit only when oriented correctly. An arrow or a missing pin on one corner of the chip will show you how to line things up.
3. Align with the triangular symbol with the processor and socket key marks, as shown in the Figure.
4. Lower the lever to lock the CPU into place.

6. Install the CPU heat sink:

You should follow the manufacturer instructions to install the heat sink and the cooling fan. If you bought an OEM CPU and a separate heat sink, then you need to spread a thin layer of the thermal grease over the chip. The thermal grease ensures proper transfer of heat.

There are some heat sinks that come with this grease already applied. In that case, you don't need to use thermal grease over the chip.

1. Attach the clip that holds the heat sink in place, keeping in mind that it may require a fair amount of force. Again, follow the instructions that came with the heat sink. They will show you how to fit it correctly. If you are in doubt, you can visit the manufacturer's website for more information.
2. Plug the CPU fan's power connector into the proper connector on the motherboard.

7. Install RAM memory:

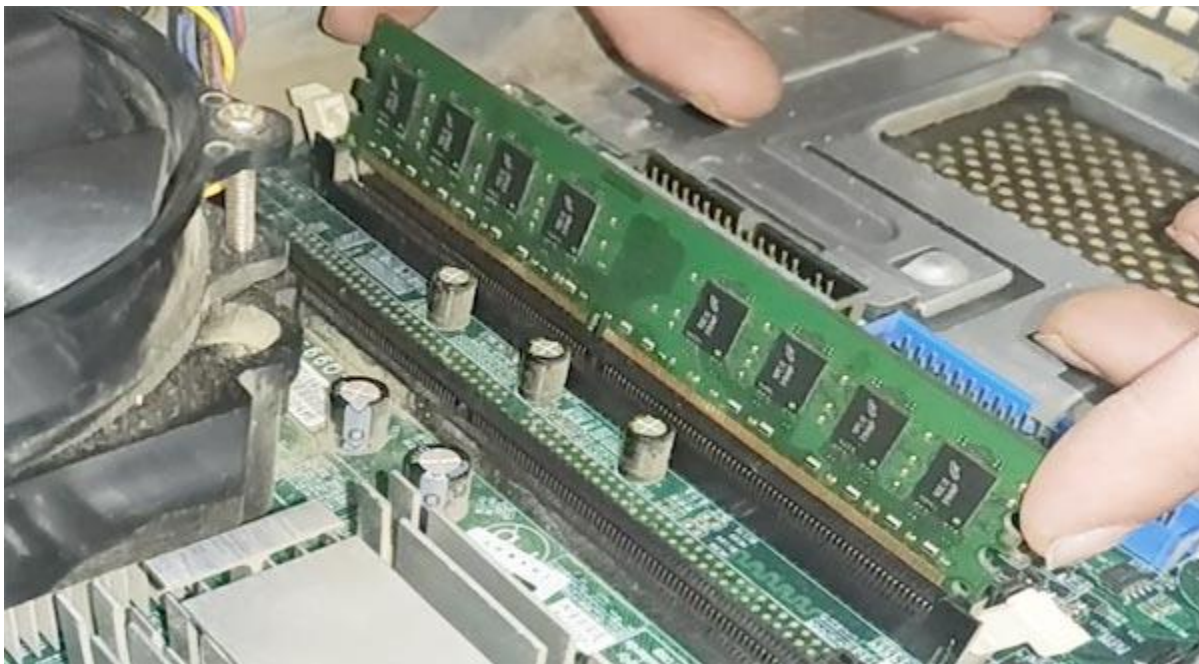

Fig: Install RAM

1. Unlock the two tabs from both ends of the RAM slot.
2. To install the RAM, insert them into the proper sockets and push down firmly but evenly until the clips on both sides of the socket pop into place. If your

motherboard supports dual-channel memory, consult the user manual to determine which pairs of RAM sockets you should use.

8. Install the Power Supply Unit (SMPS):



Fig: Install Power supply unit (SMPS)

1. Place the SMPS inside the CPU cabinet in the proper position. If you are not able to find the correct location, then check the manual.
2. Final steps, to install SMPS, you need to tighten the screw to secure the SMPS to the case.

9. To install HDD:

You can see a 3.5 inch bay inside the CPU cabinet. If you are unable to find it, then check the manual of the case to identify the bay location.

Place the HDD inside the bay properly and tighten the screw.

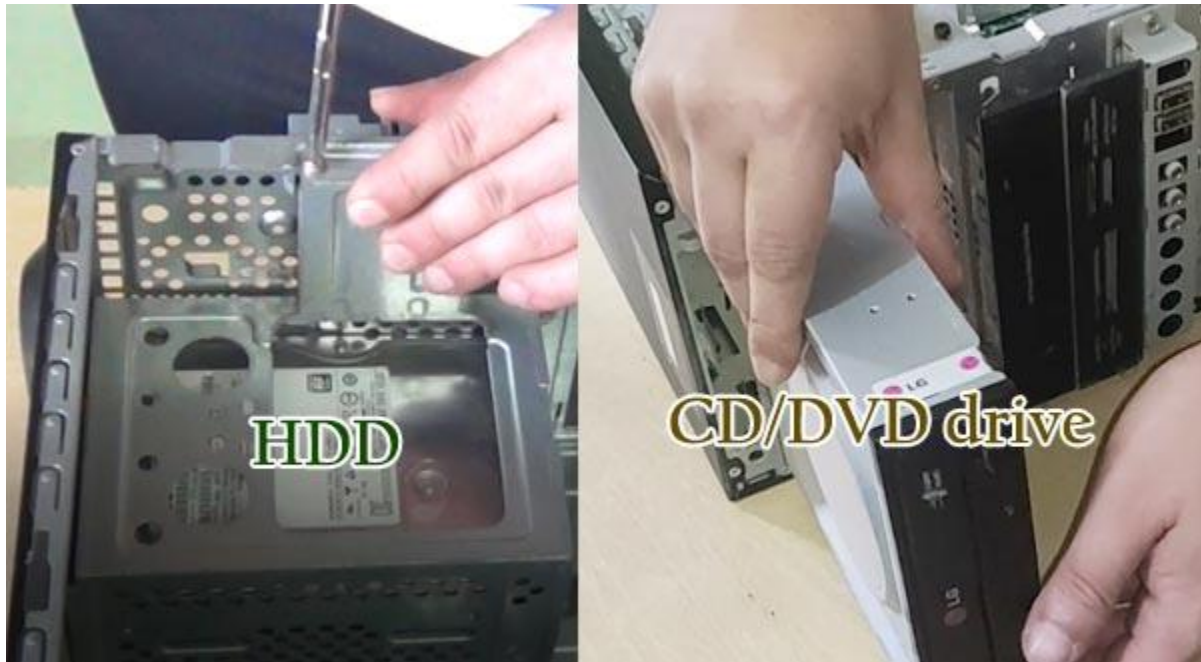

Fig: Install drives

10. To install CD/DVD:

You can see a 5.25 inch bay inside the CPU cabinet. If you are unable to find it, check the manual of the case to identify the bay location.

Place the CD/DVD inside the CPU cabinet to align with the 5.25-inch bay. And, finally, you need to tighten all the screws to hold firmly.

11. Install Expansion cards:

Expansion cards help to increase the functionality of your computer. You can place Expansion cards on the motherboard.

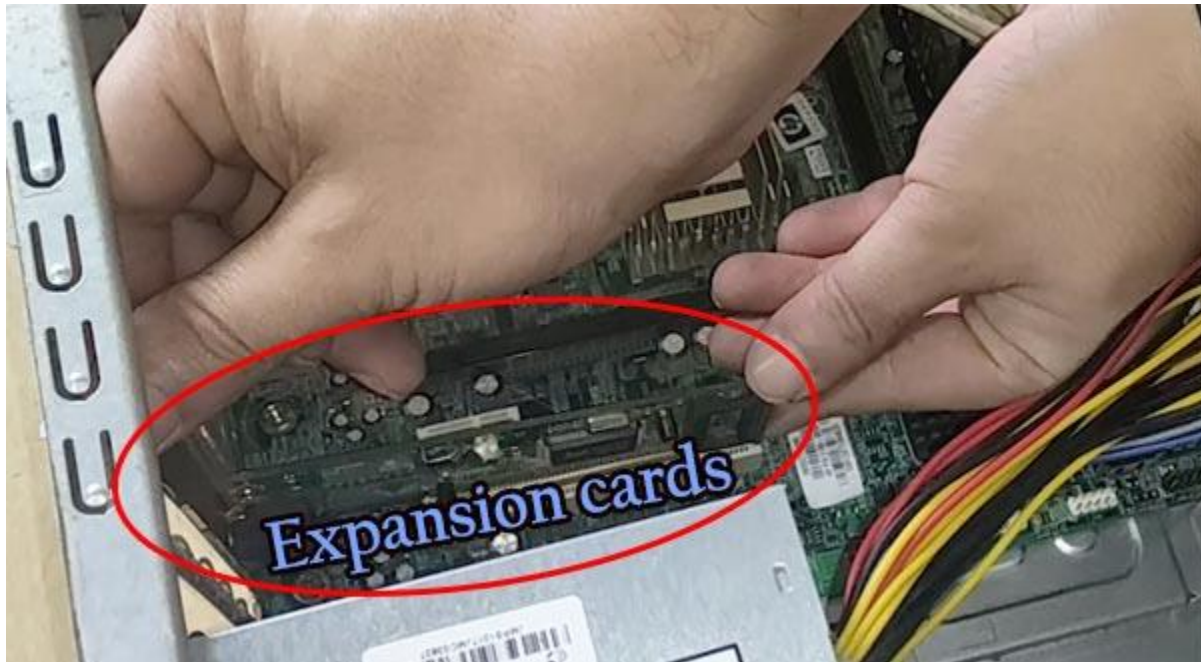

Fig: Install Expansion Cards

PCI compatible expansion cards can place on the **PCI slots** of the motherboard.

PCI-e compatible expansion cards can place on the **PCI-e slots** of the motherboard.

Video cards or graphics cards can place on the **AGP slot** of the motherboard.

You must know about [various parts of a motherboard](#) such that, you can effortlessly identify the different connectors.

12. Install Sys/Rear cooling fan:

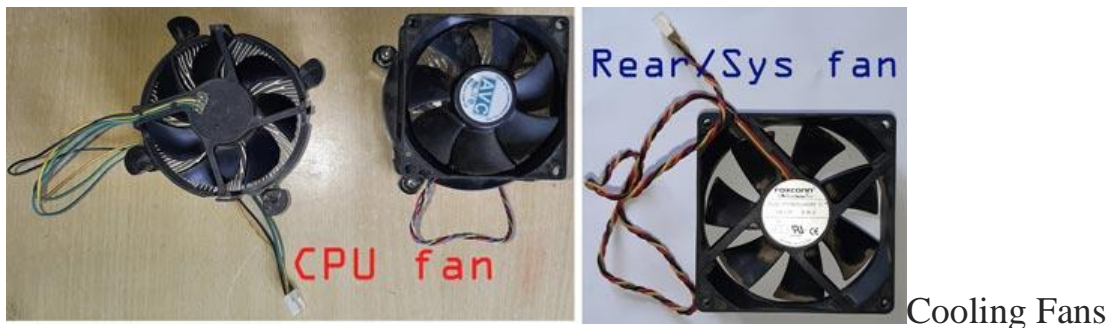

Find the location where you can place the Sys/Rear cooling Fan. Generally, SYS/Rear cooling can place below the SMPS.

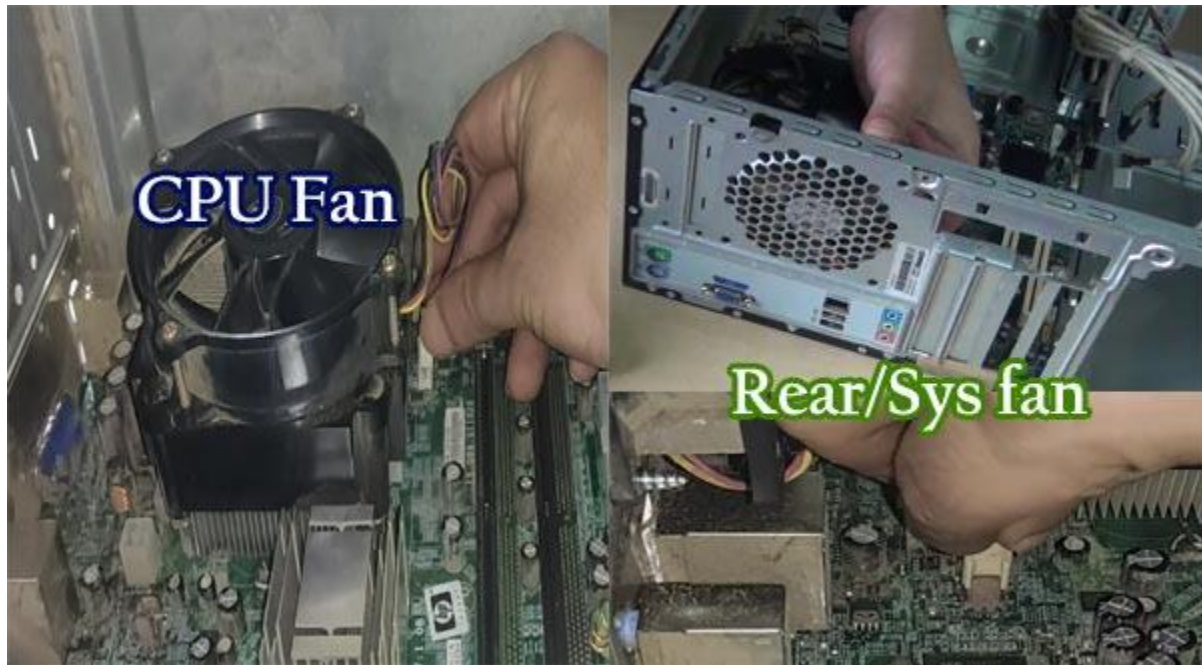

Fig: Cooling fans

13. Bus cable connection:

Amazingly, bus cable or data cable connections are prime connections. Bus cable helps to share information or data between the storage device and motherboard.



sata-pata bus and connector

If your motherboard has a SATA Bus connector, then you need to use **SATA cables**. AND if your motherboard has a PATA Bus connector, then you can use **PATA cable** or **IDE cable**.

In general, two bus cables need to connect inside the CPU. First, Bus cable connects the HDD and motherboard. And the second Bus cable connects the CD/DVD drive and motherboard.

14. Power Cable connection:

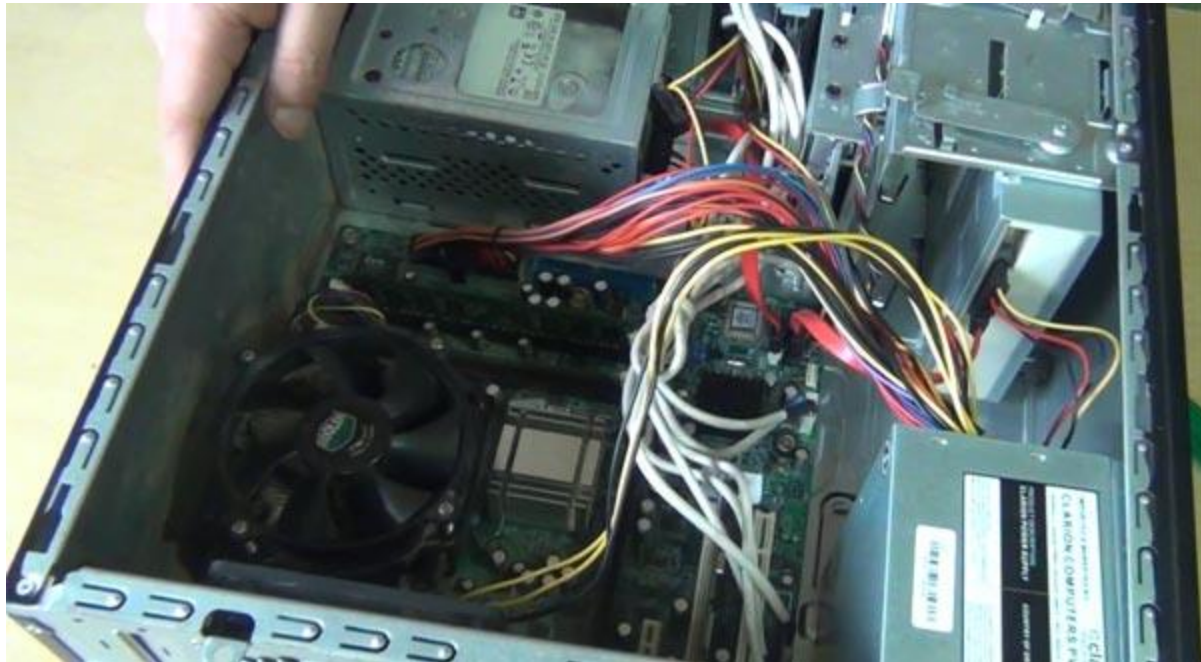

Fig: Cable connection

This one is the final step of assembling a CPU. You need to provide power to the different parts of the CPU. Plug the **ATX power connector** from your power supply into the matching port on your motherboard.

1. You can find a **20/24 pins ATX power connector port** on the motherboard. The 20/24 pins ATX power connector cable coming from SMPS needs to connect here. Check the lock system in both ends of the connector and the port, and place it properly. As always, refer to your motherboard's manual for the exact locations.
2. There is another **4-pins ATX power connector port**, you can find on the motherboard. You can locate this port near the processor socket. You must connect the 4-pins power connector in this port properly.

15. Front Panel connector connection:

Use your motherboard user manual and find the description of front-panel connectors.

First, attach each of the tiny leads from the power and reset switches. After that, the hard-disk activity lights, the PC speaker, and any front-panel USB to the corresponding pin on your motherboard.

Part2: How to assemble PC

This one is the final part of assembling a computer system.

1. Check your keyboard connector port. If it is a USB connector, then connect your keyboard into the proper USB port. And if it is a PS/2 connector, then connect to the correct, PS/2 port.
2. Same steps you need to follow to connect your mouse into the proper port.
3. You require a VGA (Video Graphic Array) cable to connect the monitor and CPU. Find the 15 pins male connector on the backside of the CPU cabinet and your monitor. Use the VGA cable to connect the CPU cabinet and the monitor. Finally, you need to tighten the lock screws.
4. If you have a speaker, you can connect the speaker on the backside of your CPU cabinet. To get sound from the speaker, you need to plug the speaker's cable with the Aux port.
5. And if you have a printer, you can connect the printer on the backside of your CPU cabinet. These days, you can connect your speaker BUS cable on the USB port. Finally, connects power to the various parts of your computer. You have to connect the power cable with the CPU case, monitor, speaker, and printer.

Check your PC Set-Up:

It is time to turn on your system and check your PC set up. Make sure the keyboard, mouse, and monitor are all plugged into the appropriate ports on the back of the PC. Plug the power cord back in, and turn the machine on.

To boot a computer you need hardware and software. Till now you have understood to assemble a computer. If you want to work on that computer you need to install an Operating System.

If you do not know **how to install an operating system** on a computer, check the following two articles:

Disassembling a PC?

Disassembling a PC means disconnecting the different components of a PC.

Steps for disassembling a PC

Generally, people want to know both assemble and disassemble steps of a computer. Therefore I am sharing my ideas to help you to assemble and disassemble a computer system.

1. Unplugged the AC power supply to the PC from the wall socket
2. Remove the Cover or chassis or case.
3. Unplugged bus cables and ATX power cables
4. Remove Adapter Cards if any
5. Now Remove the processor and the heat sink and fan
6. Remove hard disk and CD/ DVD drives
7. Next, remove the Memory Modules
8. Remove the Power Supply (SMPS)
9. Finally, Remove the Motherboard

1. Unplugged the AC power supply to the PC from the wall socket

This one is the first step to begin a PC disassemble process. Always remember first disconnect all the power supply connected to your computer system before starting to remove parts.

2. Remove the case covering

Loose the screws and remove the case covering to access the inside parts of the CPU cabinet case.

3. Unplugged bus cables and ATX power cables

Disconnect all the cables one by one inside the CPU case. First, disconnect ATX power cables from the motherboard. After that, disconnect power supply cables, bus cables from the HDD/SSD, and motherboard.

4. Remove adapter cards if any

If any adapter is connected then, disconnect the card from the motherboard.

5. Remove the processor and the heat sink and fan

Now its time to remove the heat sink from the motherboard. Generally, the CPU fan and the heat sink attach together. If it is separated in that case, you need to remove the fan first after that, you can remove the CPU heat sink.

In the final step, unlock the processor socket and remove the processor from the motherboard carefully.

6. Remove hard disk and CD/ DVD drives

Its time to remove the other parts of the computer system. Remove the Hard disk drive or SSD from the motherboard. You can also remove the CD/DVD drive from the CPU case.

Sometimes, to remove CD/DVD drive from the CPU case, you need to remove the front cover of the CPU cabinet case first. After that, you can remove the ROM drives.

7. Remove memory modules

In this process, you do remove the RAM from the motherboard. First, unlock the RAM from both ends and pull the RAM carefully.

8. Remove the Power Supply Unit (PSU)

Already you know, SMPS supplies power to the various parts of the computer system. Here you need to remove the SMPS from the CPU cabinet case.

9. Remove the motherboard

The final step of the PC disassemble process is this one. Carefully remove the motherboard from the CPU cabinet case.

Note: Remember, bolts or screws are the very essential things. They help to make rigid, all the parts used inside the computer. To remove any part from the computer system mostly, you need to take out bolts first. Here in PC disassemble steps, I have ignored that portion.

Conclusion

Assembling and disassembling a computer system is not a difficult task but requires keen observation and knowledge of the different components of the

system. You need to be extra careful when fitting in these components and make sure that they are not fitted forcefully but firmly.

In case of hardware failure or to install new add-on cards, you need to have good knowledge to assemble and disassemble a computer system

Major parts of a computer case

<https://www.youtube.com/watch?v=HB4I2CgkcCo>

Inside a computer

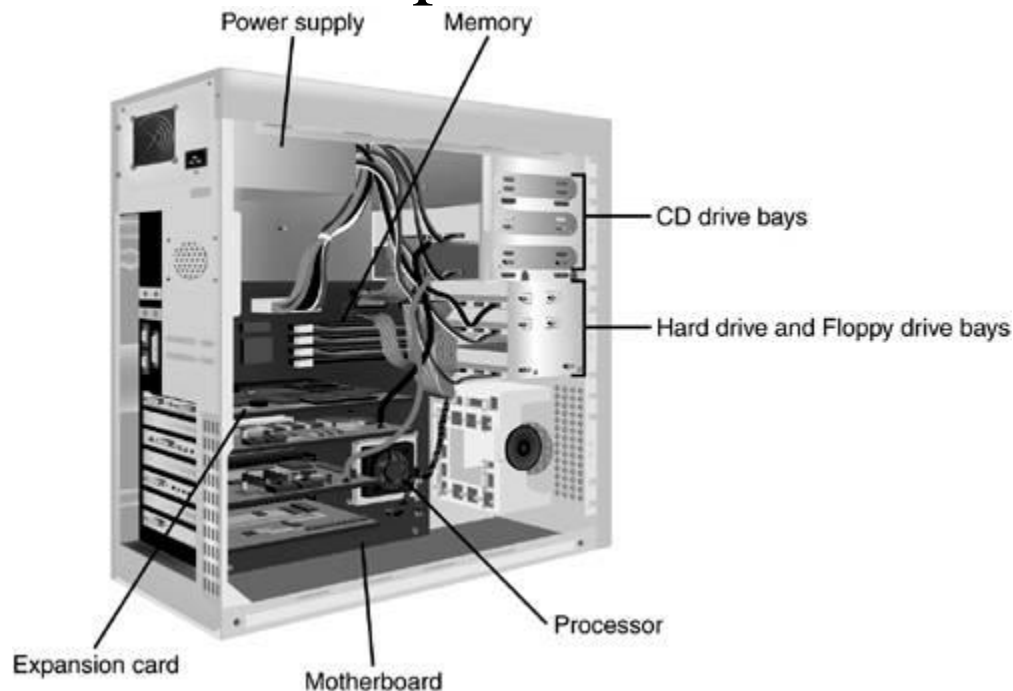

Have you ever looked **inside a computer case**, or seen pictures of the inside of one? The small parts may look complicated, but the inside of a computer case isn't really all that mysterious. This lesson will help you master some of the basic **terminology** and understand a bit more about what goes on inside a computer.

Motherboard

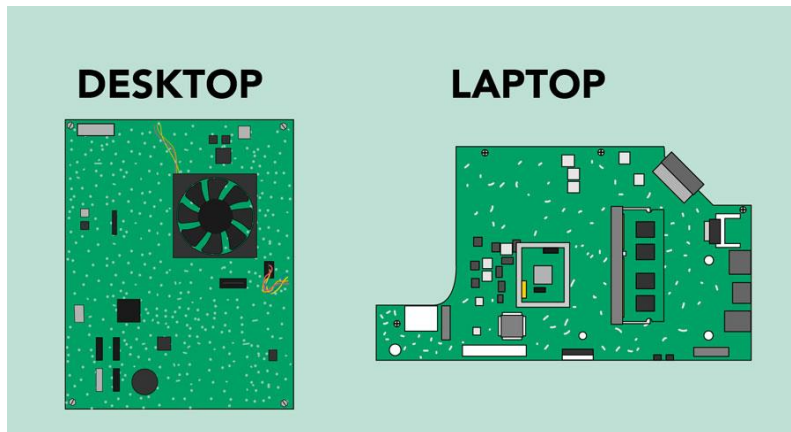

The **motherboard** is the computer's **main circuit board**. It's a thin plate that holds the CPU, memory, connectors for the hard drive and optical drives, expansion cards to control the video and audio, and connections to your computer's ports (such as USB ports). The motherboard connects directly or indirectly to every part of the computer.

CPU/processor

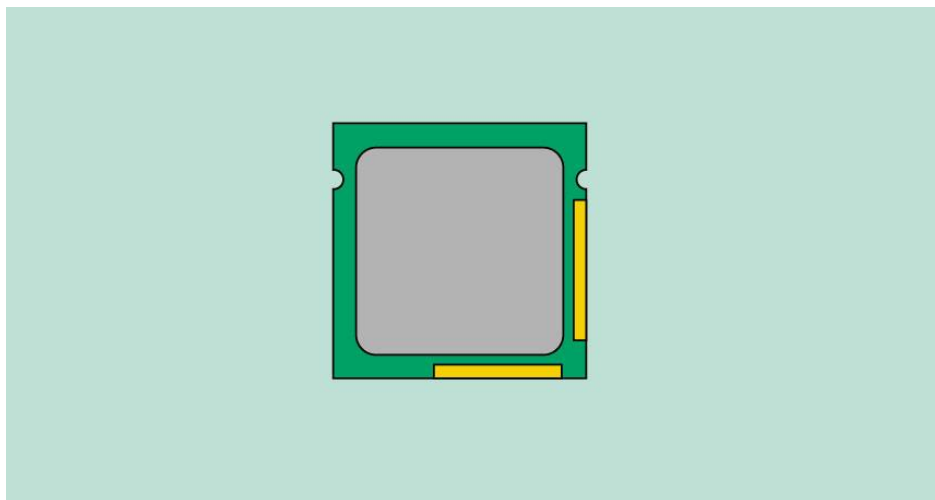

The central processing unit (CPU), also called a **processor**, is located inside the **computer case** on the motherboard. It is sometimes called the brain of the computer, and its job is to carry out commands. Whenever you press a key, click the mouse, or start an application, you're sending instructions to the CPU.

The CPU is usually a **two-inch ceramic square** with a **silicon chip** located inside. The chip is usually about the size of a thumbnail. The CPU fits into the motherboard's **CPU socket**, which is covered by the **heat sink**, an object that absorbs heat from the CPU.

A processor's **speed** is measured in **megahertz (MHz)**, or millions of instructions per second; and **gigahertz (GHz)**, or billions of instructions per second. A faster processor can execute instructions more quickly. However, the actual speed of the computer depends on the speed of many different components—not just the processor.

RAM (random access memory)

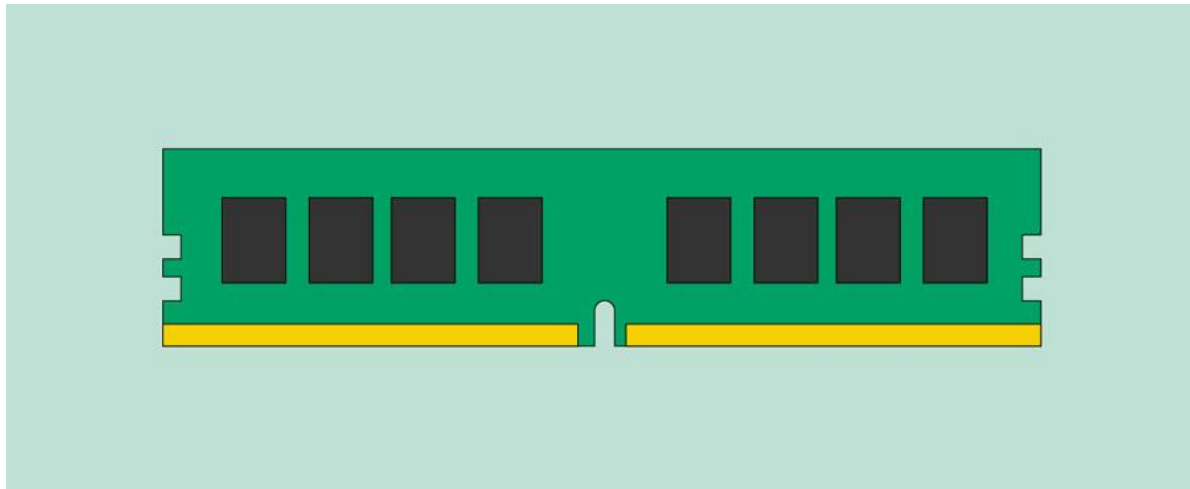

RAM is your system's **short-term memory**. Whenever your computer performs calculations, it temporarily stores the data in the RAM until it is needed.

This **short-term memory disappears** when the computer is turned off. If you're working on a document, spreadsheet, or other type of file, you'll need to **save** it to avoid losing it. When you save a file, the data is written to the **hard drive**, which acts as **long-term storage**.

RAM is measured in **megabytes (MB)** or **gigabytes (GB)**. The **more RAM** you have, the more things your computer can do at the same time. If you don't have enough RAM, you may notice that your computer is sluggish when

you have several programs open. Because of this, many people add **extra RAM** to their computers to improve performance.

Hard drive

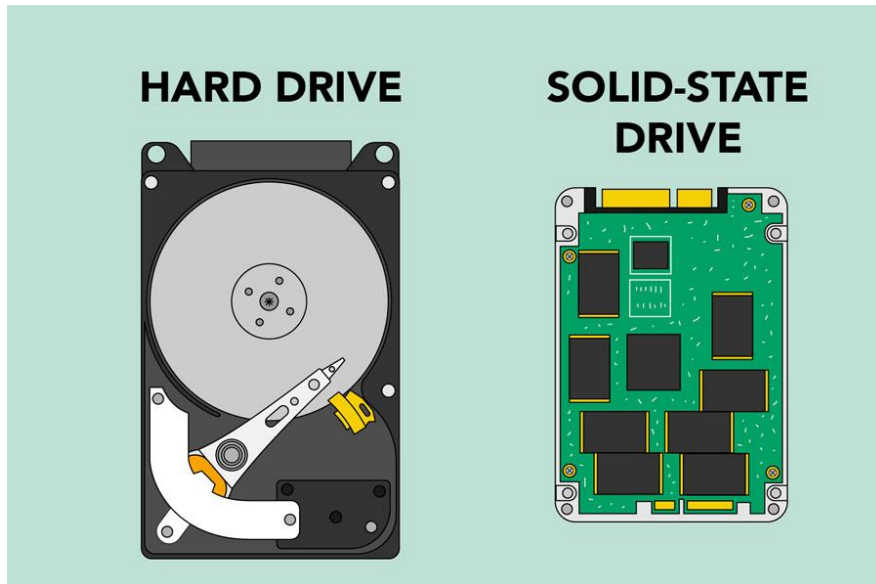

The **hard drive** is where your software, documents, and other files are stored. The hard drive is **long-term storage**, which means the data is still saved even if you turn the computer off or unplug it.

When you run a program or open a file, the computer copies some of the data from the **hard drive** onto the **RAM**. When you **save** a file, the data is copied back to the **hard drive**. The faster the hard drive, the faster your computer can **start up** and **load programs**.

Power supply unit



The power supply unit in a computer **converts the power** from the wall outlet to the type of power needed by the computer. It sends power through cables to the motherboard and other components.

If you decide to open the computer case and take a look, make sure to **unplug** the computer first. Before touching the inside of the computer, you should touch a grounded metal object—or a metal part of the computer casing—to discharge any static buildup. Static electricity can be transmitted through the computer circuits, which can seriously damage your machine.

Expansion cards

Most computers have **expansion slots** on the motherboard that allow you to add various types of **expansion cards**. These are sometimes called **PCI (peripheral component interconnect) cards**. You may never need to add any PCI cards because most motherboards have built-in video, sound, network, and other capabilities.

However, if you want to boost the performance of your computer or update the capabilities of an older computer, you can always add one or more cards. Below are some of the most common types of expansion cards.

Video card

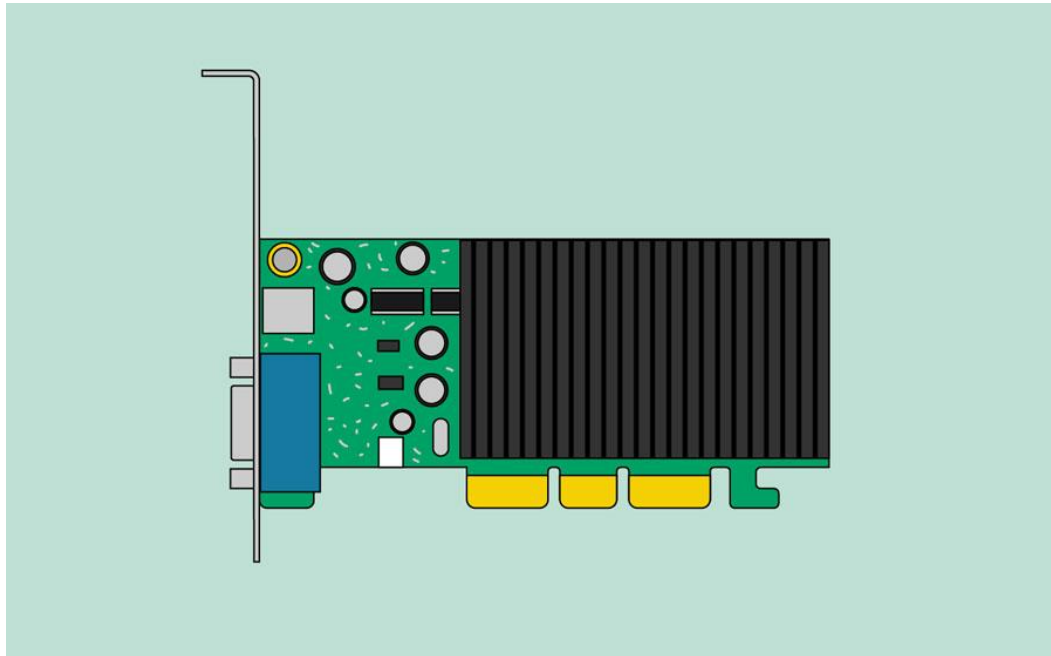

The **video card** is responsible for **what you see** on the monitor. Most computers have a **GPU (graphics processing unit)** built into the motherboard instead of having a separate video card. If you like playing graphics-intensive games, you can add a faster video card to one of the **expansion slots** to get better performance.

Sound card

The **sound card**—also called an audio card—is responsible for **what you hear** in the speakers or headphones. Most motherboards have integrated sound, but you can upgrade to a dedicated sound card for higher-quality sound.

Network card

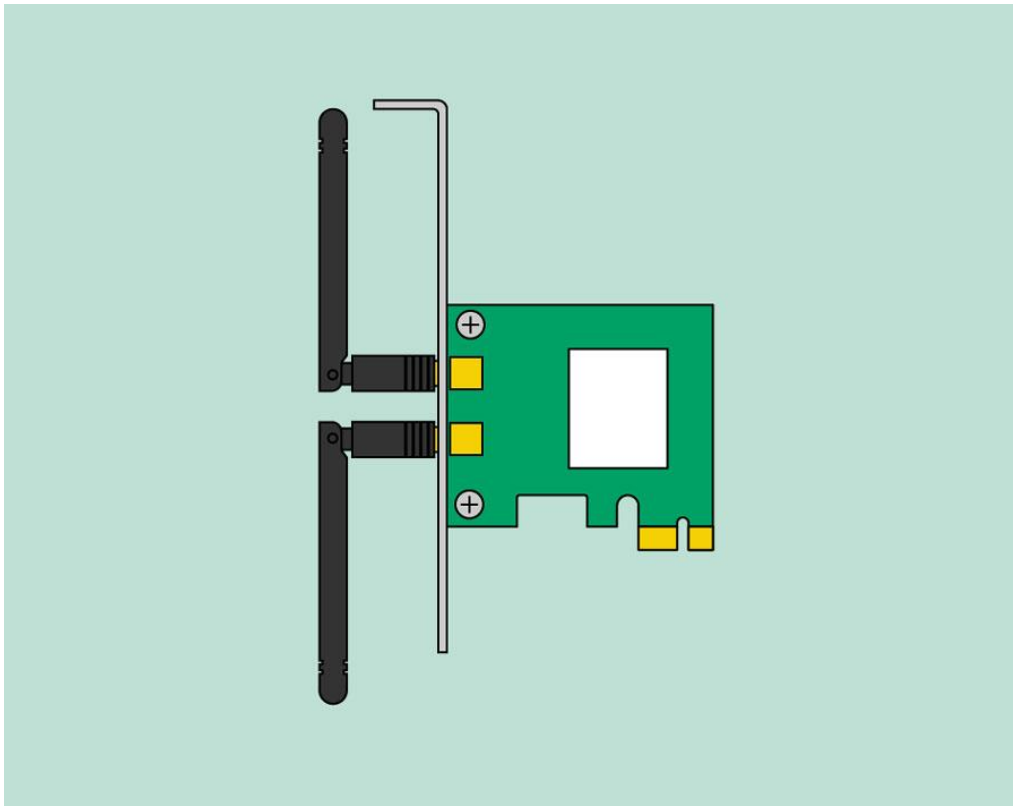

The **network card** allows your computer to communicate over a network and access the Internet. It can either connect with an **Ethernet** cable or through a **wireless** connection (often called **Wi-Fi**). Many motherboards have built-in network connections, and a network card can also be added to an expansion slot.

Bluetooth card (or adapter)

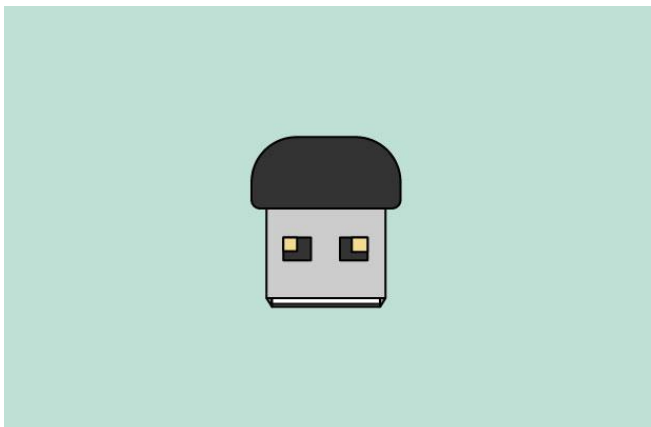

Bluetooth is a technology for wireless communication over short distances. It's often used in computers to communicate with wireless **keyboards**, **mice**, and **printers**. It's commonly built into the motherboard or included in a **wireless network card**. For computers that don't have Bluetooth, you can purchase a USB adapter, often called a **dongle**

THE MOTHERBOARD

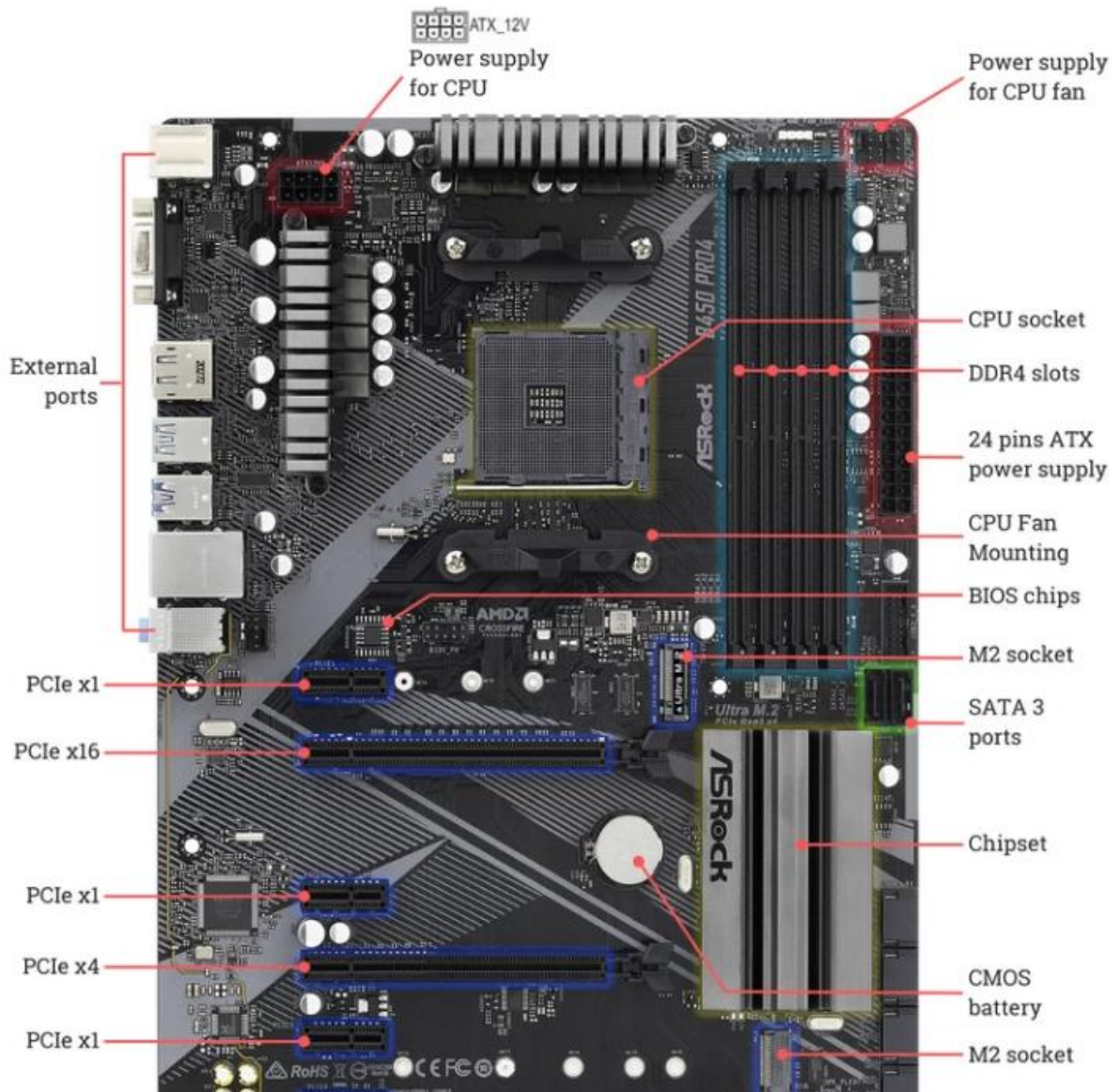

Motherboard

Definition of the Motherboard

A motherboard is the main circuit board inside a computer that connects the different parts of a computer together. It has sockets for the CPU, RAM and expansion cards and it also hooks up to hard drives, disc drives and front panel ports with cables and wires.

Motherboard is also known as a mainboard, planar board or logic board, system board, mobo or MB. It links all the individual parts of a computer together and also, allows the CPU to access and control these separate parts. Other than bridging internal components, the motherboard ports also allows you to connect external devices to the computer. Such external devices would include the monitor, speakers, headphones, microphone, keyboard, mouse, modem and other USB devices.

Functions of the Motherboard

The functions of a computer motherboard are as follows:

- i. The motherboard acts as the central backbone of a computer on which other modular parts are installed such as the CPU, RAM and hard disks.
- ii. The motherboard also acts as the platform on which various expansion slots are available to install other devices / interfaces.
- iii. The motherboard is also responsible to distribute power to the various components of the computer.
- iv. They are also used in the coordination of the various devices in the computer and maintain an interface among them.
- v. Some of the Sizes in which the motherboards are available are : BTX, ATX, mini-ATX, micro-ATX, LPX, NLX etc..

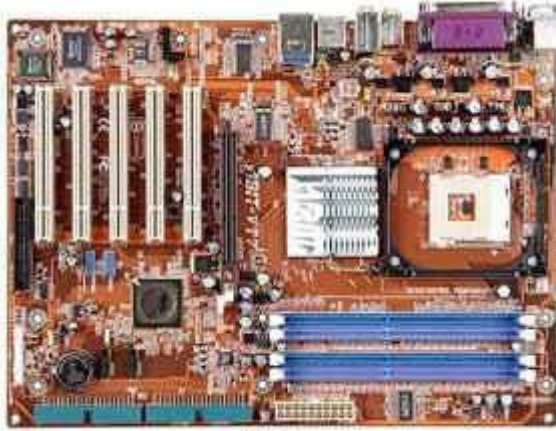

ATX



Micro-ATX

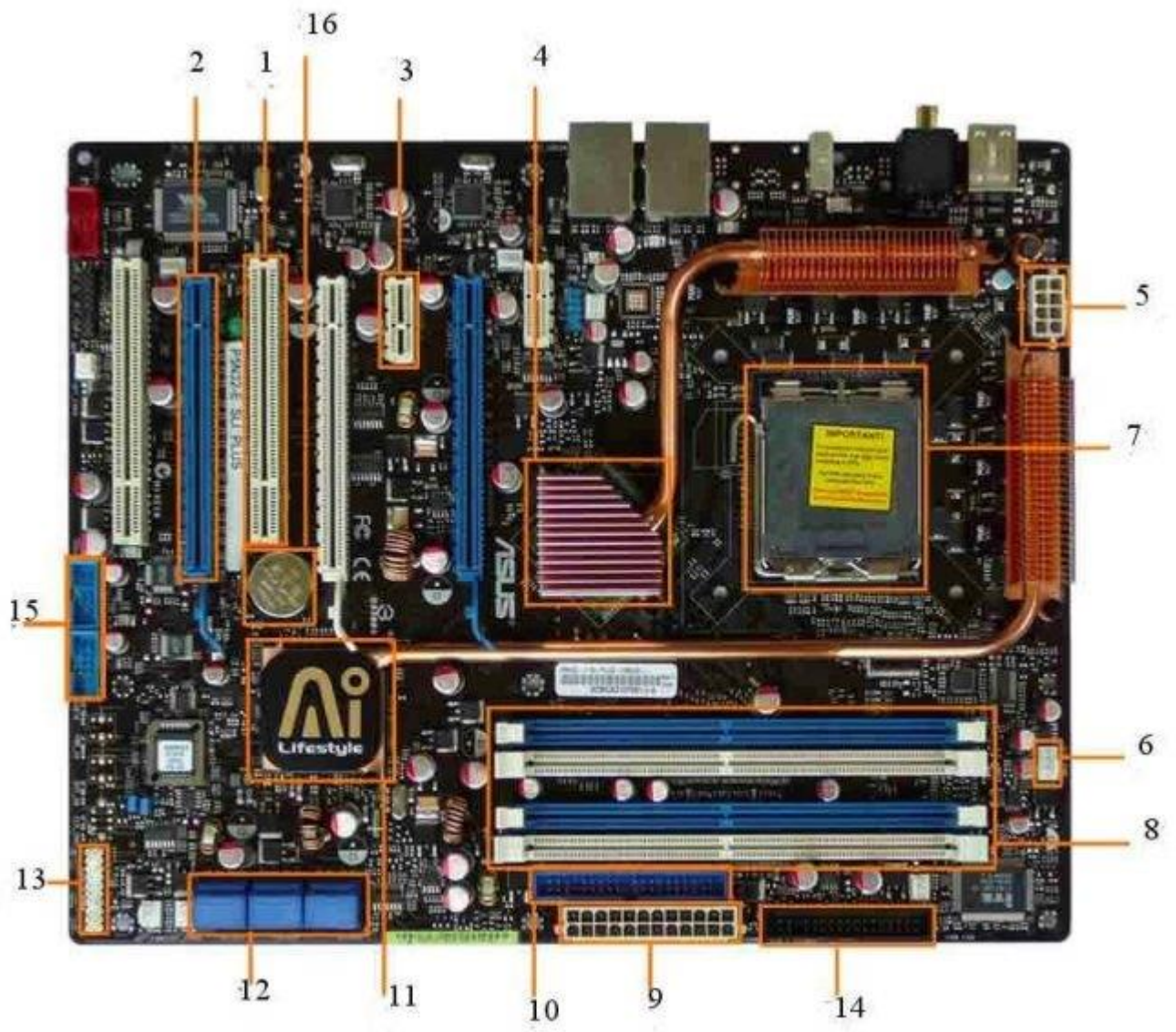

Types of Motherboards

A computer's motherboard is typically the largest printed circuit board in a machine's chassis. It distributes electricity and facilitates communication between and to the central processing unit (CPU), random access memory (RAM), and any other component of the computer's hardware. There is a broad range of motherboards, each of which is intended to be compatible with a specific model and size of the computer.

To comprehend what motherboards are and what they do, we must first examine their various types and specifications.

1. Advanced Technology (AT) motherboard

Due to their larger physical dimensions (which can be measured in hundredths of millimeters), these motherboards do not work properly with computers that fall into the category of smaller desktops. A larger physical size makes it more difficult to install new [hardware drivers](#).

The power connections on these motherboards are in the form of sockets and plugs with six prongs each. Due to the difficulty in recognizing these power connections, users often have issues while trying to connect and operate them. In the 1980s, motherboards of this sort were all the rage, and they continued to be manufactured far into the 2000s.

2. Standard ATX motherboard

ATX is an enhanced version of the AT motherboard that Intel created in the 1990s. Its name means "advanced technology extended," and its initials stand for "advanced technology." Unlike AT, it is much more compact and enables the associated components to be interchanged. The connection elements have witnessed significant progress and development.

3. Micro ATX motherboard

The length and width of these motherboards, measured in millimeters, are also 244 mm (size metrics will differ as per the manufacturer). This motherboard has fewer ports and slots than the Standard ATX board.

Users who do not want excessive connections and subsequent upgrades, like adding more RAM, an extra GPU, or other Peripheral Component Interconnect (PCI) cards, are better suited for this kind of motherboard than others.

This motherboard may be installed in any case with enough space to accommodate 244 mm by 244 mm. It can also be installed in larger cases that are compatible with Standard ATX or eXTENDED ATX motherboards.

4. Extended ATX motherboard

The dimensions of this motherboard are 344 millimeters by 330 millimeters (dimensions will differ with different manufacturers). This motherboard supports a single or a twin CPU configuration and has up to eight RAM slots.

Additionally, it has a higher number of PCIe (where e is for Express) and PCI slots, which may be used to add PCI cards for a wide range of applications. Workstations and servers are both able to use this software. There is sufficient room on all eATX motherboards, making them ideal for desktop computers, thanks to the significant space provided for airflow and the attachment of various components.

5. Flex ATX motherboard

These ATX Form Factor mainboards do not enjoy the same degree of popularity as their ATX Form Factor counterparts. They are the ones within the ATX family that are considered the most compact. They were designed to occupy a minimal amount of space and had a minimal price tag. Flex ATX is a modification of mini ATX that Intel created between 1999-2000. It is a motherboard standard.

6. Low-Profile EXtended (LPX) motherboard

In comparison to previous iterations, this has two significant enhancements. The first change was that the output and input ports were moved to the rear of the device, and the second change was the addition of a riser card, which enables the device to have additional slots and makes it easier to attach components.

There is an implementation of some of these functionalities on the AT motherboard. The primary drawback of this board is that it does not have any accelerated graphic port (AGP) ports, resulting in a connection to PCI that is made directly. The new low-profile extended (NLX) boards are where issues present in these motherboards have been addressed.

7. BTX motherboard

Balanced technology extended, abbreviated as BTX, is a strategy developed to fulfill the requirements of emerging technologies, which call for increased power consumption and, as a result, emanate more heat. During the middle of the 2000s, Intel ceased the future production of BTX boards to concentrate on low-power CPUs.

8. Pico BTX motherboard

Given their diminutive size compared to a typical motherboard, these boards are called Pico. Even though the upper half of the BTX is shared, support is provided for two expansion slots. Its distinguishing characteristics are the half-height or riser cards, and it is designed to meet the needs of digital applications.

9. Mini ITX motherboard

It is important to note that there is no regular-sized version of the information technology extended (ITX) motherboard. In its place, the motherboard has been downsized into a more compact form than in earlier iterations. It was developed in the 2000s, and its measurements are 17 by 17 centimeters.

Due to its reduced power consumption and quicker cooling capabilities, it is primarily used in computers with a small form factor (SFF). Given that it has a relatively low level of fan noise, the motherboard is the one that is

recommended the most for use in home theater systems because it will enhance the overall performance of the system.

10. Mini STX motherboard

The name “Intel 5×5” was initially given to the motherboard now known as the Mini-STX, which stands for mini socket technology extended. Although it was introduced in 2015, the motherboard has dimensions of 147 millimeters by 140 millimeters. This converts to a length of 5.8 inches and a width of 5.5 inches; hence, the 5×5 name is rather misleading.

The Mini-STX board is 7 millimeters longer from front to back, making it somewhat rectangular in shape. This is in contrast to the shape of other tiny form factor boards, like the Next Unit of Computing (NUC) or the mini-ITX, which are square.

Key Components of a Motherboard

The following are the key components of a motherboard:

Key Components of a Motherboard

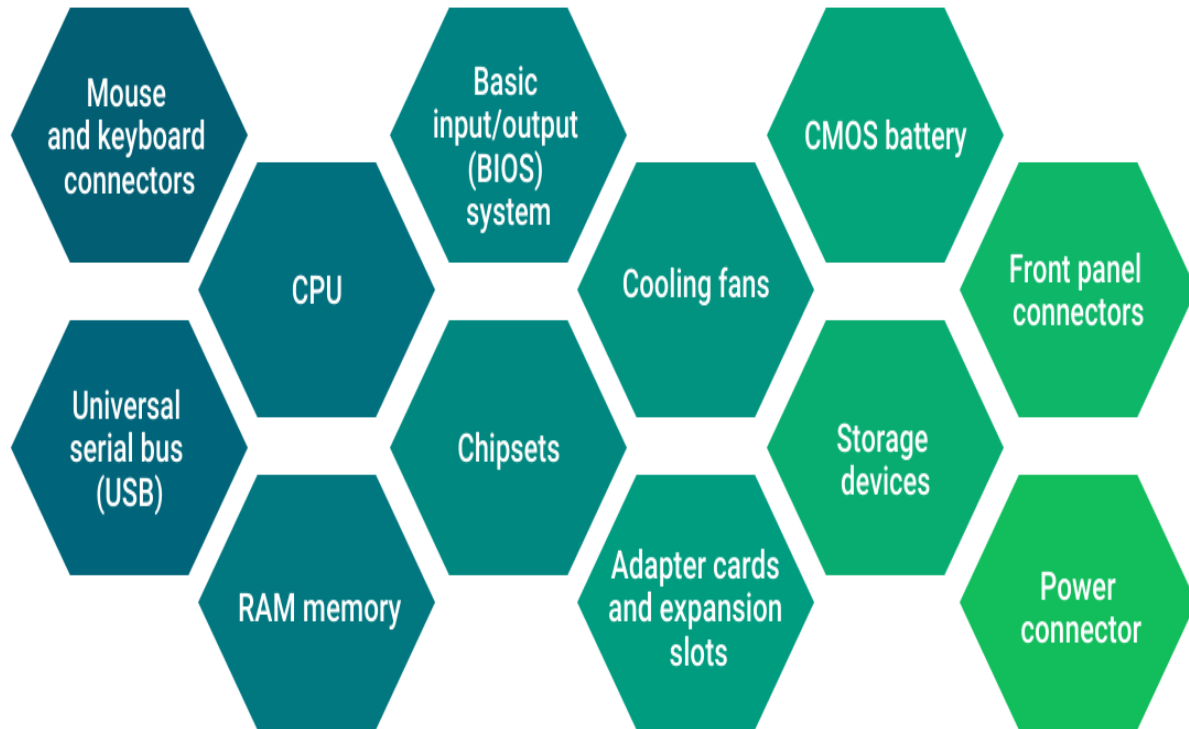

1. Mouse and keyboard connectors

Computer motherboards must have two separate connectors that allow users to connect their external mouse and keyboard. These connectors are responsible for sending instructions and receiving responses from the computer. There are two keyboard and mouse connectors, the PS/2 and the USB. The personal system/2(PS/2) port is a mini-DIN plug that contains six pins and connects the mouse or keyboard to an IBM-compatible computer. Other computers use the USB port to connect the mouse or keyboard.

2. Universal serial bus (USB)

The USB is a computer interface that connects computers to other devices, such as phones. The USB port is a significant part of a motherboard that allows users to connect external peripheral devices such as printers, scanners, and pen drives to the computer. Moreover, it enables users to transfer data between the device and the computer. A USB port allows users to connect peripheral devices without restarting the system. Types of USB include USB-A, USB-B, USB-mini, micro-USB, USB-C, and USB-3.

3. CPU

The central processing unit (CPU) is commonly referred to as the computer's brain. The CPU controls all the functions of a computer. CPUs are available in different form factors, each requiring a particular slot on the motherboard. A CPU can contain one or multiple cores. A CPU with a single core can only perform a single task at a time, while those with multiple cores can execute multiple tasks simultaneously.

4. RAM memory

RAM slots connect the random access memory (RAM) to the motherboard. RAM allows the computer to temporarily store files and programs that are being accessed by the CPU. Computers with more RAM capacity can hold and process larger files and programs, thus enhancing performance.

However, RAM contents are erased when the computer is shut down. A computer usually has two RAM slots. However, some computers have up to four RAM slots in the motherboard to increase the available memory.

5. Basic input/output (BIOS) system

The BIOS contains the firmware of the motherboard. It consists of instructions about what to do when the computer is turned on. It is responsible for initializing the hardware components and loading the computer's operating system. The BIOS also allows the computer's operating system to interact and respond with input and output devices such as a mouse and keyboard.

In some motherboards, the legacy BIOS is replaced by the modern extensible firmware interface (EFI) or the unified extensible firmware interface (UEFI). UEFI and EFI allow the computer to boot faster, provide more diagnostic and

repair tools, and provide a more efficient interface between the operating system and computer components.

6. Chipsets

The chipsets of a computer control how the computer hardware and buses interact with the CPU and other components. Chipsets also determine the amount of memory users can add to a motherboard and the type of connectors that the motherboard can have.

The first type of chipset is the northbridge chipset. The northbridge manages the speed at which the CPU communicates with the components. It also controls the processor, the AGP video slot, and the RAM.

The second type of chipset is the southbridge chipset. The southbridge chipset controls the rest of the components connected to the computer, including communication between the processor and expansion ports such as USB ports and sound cards.

7. Cooling fans

The heat generated when electric current flows between components can make a computer run slowly. If too much heat is left to build up unchecked, it could damage computer components. Thus, a computer performs better when kept cool. Cooling fans increase the airflow, which helps to remove heat from the computer. Some elements, such as video adapter cards, have dedicated cooling fans.

8. Adapter cards and expansion slots

Adapter cards are integrated into the motherboard to enhance a computer's functionality. Examples include sound and video adapters. The expansion slots allow users to install compatible adapter cards. Examples of expansion slots include the peripheral component interconnect (PCI) slot, the AGP slot (which enables the insertion of video cards), the PCI Express serial bus slot, and the PCI-extended slot.

9. CMOS battery

The CMOS battery is a small round battery found on the motherboard of every computer. It provides power to the complementary metal oxide semiconductor (CMOS) chip. The CMOS chip stores BIOS information and computer settings, even when powered down. The CMOS battery allows users to skip resetting BIOS configurations, such as boot order, date, and time settings, each time they power on their computer.

10. Storage devices

Storage drives store data permanently or retrieve data from a media disk. The storage devices can either be installed in the computer as hard drives or in removable drives that can connect to the computer through the USB ports. [Hard disk drives\(HDD\) or solid-state drives \(SSD\)](#) are computers' primary storage drives. Computers with SSDs execute tasks much faster and perform better than HDDs. Users can also use optical drives such as compact discs to store information.

11. Front panel connectors

Front panel connectors connect the light-emitting diode (LED) lights on the front of the case to the hard drive, the power button, the reset button, and the internal speaker for testing. Some USB and audio devices also have LED lights.

These front panel connectors are usually plugged into small pins on the motherboard. Although the pins are grouped and color-coded, their layout structure varies depending on the model of the motherboard.

12. Power connector

The power connector provides an electric supply to the computer to function as intended. The power supply connector has 20 pins and converts 110-V AC power into +/-12-Volt, +/-5-Volt, and 3.3-Volt direct current (DC) power.

Functions of a Motherboard

The following are seven functions of a motherboard:

Functions of a Motherboard



Manages data flow



Conserves resources



Optimizes power distribution



Drives communication



Enhances performance



Improves reliability



Enables productivity

1. Manages data flow

The BIOS component of the motherboard ensures that the operating system interacts well with input and output devices, such as the keyboard and mouse, to process instructions. This ensures that the data sent to the computer moves as expected to perform the intended purpose. It also manages data flow through its USB ports, allowing for data transfer between devices. Additionally, it ensures the processor can access information from the RAM to boost efficiency.

2. Conserves resources

The motherboard saves consumers time, energy, and money by connecting all the computer connects. The motherboard provides a platform on which manufacturers can connect all the necessary components to ensure that the computer functions. Thus, saving consumers' time and energy as they do not have to assemble and connect different parts manually. Moreover, collecting the individual components can prove costly as consumers would be forced to incur additional transport and other miscellaneous costs.

3. Optimizes power distribution

The motherboard provides and distributes power optimally. Computers require electricity to function. The motherboard has a power connector plug

that connects the computer to a power source and converts it into a form of electrical power that the computer can use. After that, the motherboard ensures that the electric current is distributed optimally to different system components.

The motherboard has an integrated circuit technology with pre-defined connections that ensure each element gets the necessary power. Moreover, the circuits ensure less energy is consumed to make the computer an energy-efficient machine.

4. Drives communication

The motherboard makes communication between different components easier. For a computer to process a particular set of instructions, sometimes it may require several components to communicate and work together to complete the task. In such scenarios, the motherboard relies on its circuit technology to enable communication between these components. The motherboard may also depend on some of its components, such as the CPU, BIOS, expansion ports, and USB ports, to interact with the computer's operating system.

5. Enhances performance

The motherboard boosts the capabilities of a computer. Motherboards often transform the capabilities of a computer. For instance, they have additional features and functionalities, such as built-in sound and video capabilities that can enhance the computer's output. Motherboards also allow users to connect peripheral devices such as printers, enabling computers to perform additional tasks such as printing documents. Additionally, users can expand and upgrade factory-made motherboard parts such as memory slots or hard disks to boost the capabilities of their computers.

6. Improves reliability

A good motherboard boosts the overall reliability of the computer. A high-quality motherboard provides a stable foundation for its components to operate on. A good motherboard has proper cooling, and its integrated circuit technology is set in place. These factors enable it to control the computer's hardware efficiently by ensuring that each element functions as expected and

communicates with the other components. A reliable computer performs tasks efficiently and thus enhances the user experience.

7. Enables productivity

The motherboard reduces effort duplication and simplifies work for computer users. While traditional computers came pre-installed with BIOS, modern ones are pre-installed with EFI and UEFI. BIOS, EFI, and UEFI enable computers to boot without requiring users to reconfigure basic settings, time, and date. They also load the operating system into the memory. Therefore, these motherboard components allow users to focus on other productive tasks.

How to Recycle Motherboards

Take your motherboards to an e-waste recycling center. An e-waste recycling center will responsibly break down the motherboard and safely dispose of the parts that contain toxic waste.

Take your motherboards to a major retail chain that specializes in computers and electronics. Many major retail stores will recycle your motherboards either for free or for a small fee. Examples of participating retail chains that will recycle your motherboards are Best Buy and Staples.

Send your motherboard back to the manufacturer. In most cases, the computer manufacturer can repair or upgrade the motherboard, then place it in a used or refurbished computer. They may also recycle the motherboard and use the materials to create a new motherboard.

Take your motherboard to a computer refurbisher. A computer refurbisher can often repair your motherboard and place it in another computer for reuse.

Advertise your motherboard for sale in local classified ads. Local newspapers, magazines, and websites such as Craigslist or eBay Classifieds can be taken

advantage of for selling your motherboard to a refurbisher, computer hobbyist, or to a person who enjoys making crafts from electronics.

Post your motherboards for sale on websites that attract a nationwide or global audience. Some individuals may be looking for a motherboard of a specific make and model, or style.

Reuse motherboard by making items such as jewellery, toy cars, and chandeliers



Computer buses

Buses of computer system

1. Address bus
2. Data bus
3. Control bus

The buses connect the CPU (microprocessor) to each of the memory and I/O devices. The CPU is involved in sending or receiving information to or from memory location, input or output device, and a secondary memory device (FDD or HDD).

When the CPU sends data to a device or memory, it is called WRITE operation and when the CPU receives data it is called READ operation. The functions of buses are described now.

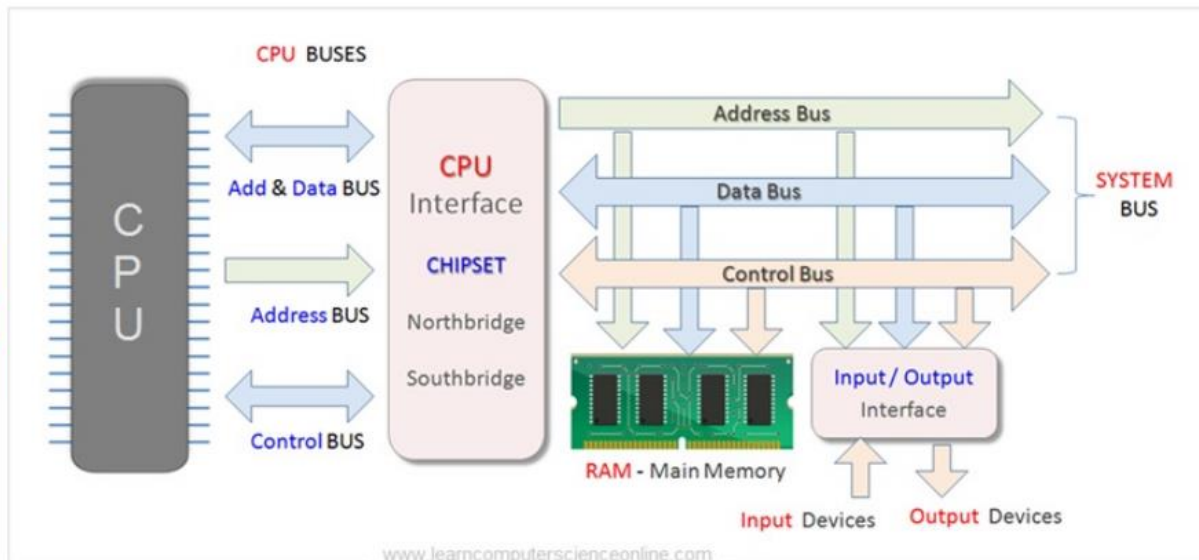

Address Bus

The address bus is unidirectional, information flows over it only in one direction, from the CPU to the memory or I/O devices. The CPU generates addresses on the lines of the address bus. Each of the addresses corresponds to one memory location or one I/O device.

When the CPU wants to communicate with (READ or WRITE), a certain memory location or I/O device, it places the appropriate address on its address output.

This address is then decoded to select the desired memory location or I/O device. This decoding process usually requires address decoder circuits.

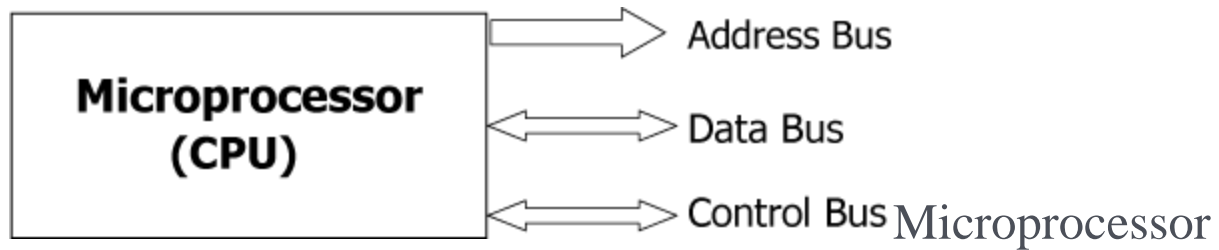

local buses

Data Bus

The data bus is bidirectional and data can flow to the CPU through it. The data bus can be either input or output depending on whether the CPU performs a READ or a WRITE operation.

During READ operation the data bus receives data that has been placed on the data bus by memory or I/O device selected by the address. During WRITE operation the data bus acts as the output and places data on the data bus which are sent to a selected memory location or I/O device.

Control Bus

The control bus consists of a set of signals that are used to synchronize the activities of separate microcomputer elements. Some of these control signals are sent by the CPU to the other components to tell them the type of operation in progress.

The I/O devices can send control signals to the CPU. Read/Write, Rest, and interrupt are examples of control signals used in a microcomputer.

Other buses

Computer System Bus Functions

BUS TYPE	BUS FUNCTION
Internal Buses	To connect the internal components of computer system such as processor , RAM , chipset , hard disk .
External Buses	To connect the external components with computer system such as monitor , keyboard , printer .
Data Bus	To connect the CPU (Processor) with main memory RAM and other components connected to computer system .
Address Bus	To connect the CPU (Processor) with main memory RAM . Carries memory addresses for read or write operations
Control Bus	To connect the CPU (Processor control unit) with main memory RAM and other components connected to computer system .Carries control signals for components .
System Bus	To connect the CPU (Processor) with main memory RAM and other important components .System bus is also referred as FSB - front side bus or memory bus. It Consist of data , address and control buses together .
Expansion Bus	To connect the CPU (Processor) with PCI OR PCI Express slots where add on cards such as graphics card , sound card can be installed to enhance system performance
Input / Output Bus	To connect the CPU (Processor) with main memory RAM and input output devices through Southbridge (input output controller)

COMPUTER MONITOR OR VIDEO DISPLAY UNIT TYPES, AND FEATURES

VDU



1. Short for **visual display unit**, **VDU** is an any device used with computers to display text and images. For example, a flat-panel display and a projector are both examples of VDUs. However, VDU most commonly describes the CRT (cathode ray tube) monitor, a now archaic standard replaced by flat-panel display methods like LED (light-emitting diode).

Early VDUs had a 13" screen size. By the mid-1990s, 15" and 17" VDU screen sizes became more common, with some 20" screen sizes being released. By the early 2000s, flat-panel monitors with 15" and 17" screen sizes gained popularity and started replacing CRT monitors.



2. Short for **video display unit**, **VDU** is a computing device that allows input from a user and output to a display, like a computer monitor. A VDU consists of a display device and a keyboard and could include a mouse. In the United States, it is sometimes known as a video display terminal or VDT (video display terminal).

Please note

The computer monitor is an output device that is used to display (softcopy) data that is processed on the system unit. A computer monitor is also known as a screen or Visual Display Unit (VDU).

Some types of computer monitors are CRT, LCD, TFT, Plasma, OLED, LED, touch screen, and curved screens. To acquire a new computer screen, some of the features to consider are resolution, size, technology, refresh rate, video connector, aspect ratio, and viewing angle among other factors.

Types of Computer monitors

Computer monitors have evolved from the bulky big Cathode Ray Tube monitor to the ultra-slim curved screen that we have today. Some of the computer monitor types that you will find in the market include:

1. Cathode Ray Tube (CRT).

These are the oldest types of computer monitors and they used the technology of cathode rays. On the back of the screen, there is a cathode gun that shot rays through a vacuum into the screen. The screen has an anode and material that glows when hit by the electrons.

The rays hit the glowing material and the image is created appropriately. The monitor had a long back side because the front and cathode gun had to be at a distance for it to give the best results.

2. Liquid Crystal Display (LCD).

They used the crystal liquid which is easy to be manipulated and changed when light strikes it. Compared to CRT they are lightweight, slimmer, and use less power.

3. Light emitting diode (LED)

It uses the light-emitting diode as the backlight which makes it slim because it doesn't need the distance that is required in CRT. They produce images with high resolution, are slimmer, less bulky, and produce less heat and less power.

4. Organic Light Emitting Diode (OLED)

It is the latest technology (an improvement from LED) but still very expensive to produce in bulky. It has an organic substrate that glows when electricity is passed through it. They use less power and they are even slimmer because they don't need backlight since the substrate can produce light.

5. Touchscreens monitors

Currently, computer screens are manufactured to take instruction from the human touch. An operating system such as Microsoft Windows 8 and above versions was developed to support a touch screen operation. There are 4 main technologies used for touch screens.

a. Capacitive touch screen

These screens use the capacitor concept which stores charge. Since the human body has electrical charges when you touch the screen at a specific position you discharge that particular point. The information is then sent to the processor which interprets what needs to be done. They are mostly used on smartphones in today's applications.

b. Resistive touch screen

The resistive screen uses the concept of resistors where it has two layers with a gap between them. For it to be effective the user has to press and not just touch because the two layers must make contact at the point where it has been pressed. When it is pressed the point can be identified and interpreted appropriately. These touch screens can be touched with a finger and any other object

that can exact pressure and not a must that it has electrical changes.

c. Infrared touch monitors

They have an infrared emitter and receiver which create an invisible grid of rays. When you touch the screen you disrupt the ray transmission which is then recorded as a touch.

d. Surface acoustic wave monitor

These touch screens use sound waves to detect the touch. They have transducers and receivers on the opposite corners of the screen. When you touch the screen you disrupt the sound wave which is sensed as a touch command.

6. Plasma display panel

They are flat-panel types of screens made up of small cells containing plasma. Plasma contains charged particles (ions and electrons). When electricity is passed through them they emit light which forms an image. They are not common computer screens because they are more economical for big-size screens.

7. Curved computer monitor

These are replacing flat screen monitors by offering a curved viewing screen. They offer a better viewing angle compared to a flat screen

Factors to consider when choosing a good computer monitor

1. **Resolution:** It is the number of pixels that can be displayed per inch of the screen. The higher the number the more clear the image that is displayed.
3. **Aspect ratio:** It is the ratio of the length (horizontal) and width (vertical) of the monitor. It determines how the image will be stretched on the screen. The main ratios are 4:3 and 16:10.
4. **Viewing angle:** It is the angle where you can view the image without distortion. CRT screens had a wide viewing angle than LCD screens.
5. **Power consumption:** LCD uses the least power compared to CRT and OLED type of technology. Less power means power is conserved and also it reduces overheating.
6. **Technology:** screen comes from different technology modes as discussed in different types above. The technology will determine the image quality, cost, and user preference.
7. **Connector video input:** latest video connector for monitors is HDMI. However, to be on the safe side you should have a computer screen that supports more than one way of connecting. If you are buying a screen for an already existing system unit make sure you check which is a compatible type of supported connection.
8. **Ergonomics:** most users spend more time on the screen and would like to get a screen design for comfort. Select a screen that has height adjustability, and can change screen brightness and contrast among other designs.
9. **Refresh rate:** this is the rate at which the screen can refresh the displayed image per second. A higher refresh rate means the image will be clear and it will not look like it hangs. It is measured in hertz and the higher the better. Most computer screens have 144Hz.

10. **Contrast and brightness:** contrast ratio is how dark the black part is and how bright the white parts of an image can get. While brightness is the measure of light that the screen can produce.
11. **Built-in speakers:** latest monitor come with an inbuilt speaker that can be used to complement the system unit speakers.
12. **USB port:** USB port is a common connector interface in today's devices including screens. They can be used to load data without even connecting to the system unit. For future improvement and use, you can select a monitor that has a USB port.

Types of computer screen connectors

Every computer offers a connection port that allows the computer monitor to be connected to the system unit so that it can receive data being transmitted.

Most monitors are connected using a VGA cable. The cable connects the VGA card which translates the information from the system unit into images and text that the user can be able to view.

Other screen connectors are AUX, HDMI, DVI, and Display Port.

Structure of Visual Display Unit

The structure of a Visual Display Unit (VDU) can vary depending on the specific type of device, but most VDUs have several key components in common. Here is a general overview of the structure of a VDU:

1. **Display panel:** This is the part of the VDU that actually displays the visual information. It is typically made of a thin layer of crystal or plastic, and can display images using a variety of technologies, such as **liquid crystal display** (LCD) or organic **light-emitting diode** (OLED).
2. **Backlight:** Many VDUs, especially those used in portable devices, use a backlight to illuminate the display panel. This helps to make the images on the screen more visible in low light conditions.
3. **Circuitry:** The VDU contains a number of electronic circuits that control the display panel, the backlight, and other components of the device.
4. **Housing:** The VDU is typically enclosed in a housing or casing that protects the internal components and provides a way to mount the device.
5. **Input/output (I/O) ports:** The VDU may have one or more I/O ports that allow it to receive data or signals from other devices, such as a computer or a cable TV box.
6. **Power supply:** Most VDUs require a source of power, which may be supplied through a power cord or a built-in battery.

Functions of Visual Display Unit

Some specific functions of a VDU include:

1. **Displaying text and graphics:** VDUs use a screen to display text and graphics, which can include text documents, spreadsheets, websites, and more.
2. **Providing a visual interface:** VDUs allow users to interact with a computer or other device by providing a visual interface through which users can see and understand the information being processed and input commands and data.
3. **Allowing for multitasking:** VDUs allow users to work on multiple tasks at the same time by displaying multiple windows or programs on the screen.
4. **Supporting high-resolution displays:** Some VDUs support high-resolution displays, which can provide a more detailed and accurate representation of the information being displayed.
5. **Providing connectivity:** VDUs may have connectivity options, such as HDMI or DisplayPort, which allow users to connect the VDU to other devices, such as a computer or a television.

Uses of Visual Display Unit

Visual Display Units (VDUs), also known as computer monitors, are used in a wide range of applications. Some common uses of VDUs include:

1. **Office work:** VDUs are commonly used in office environments to display text documents, spreadsheets, and other business-related information.
2. **Education:** VDUs are used in classrooms and educational settings to display educational materials and videos, and to allow students to interact with educational software.
3. **Entertainment:** VDUs are used to display movies, television shows, and video games, and they can also be used to access streaming services like Netflix or Hulu.
4. **Gaming:** VDUs are often used in conjunction with gaming consoles or PC gaming systems to display video games.
5. **Design and graphics:** VDUs are used by designers and graphic artists to create and edit graphics and other visual content.
6. **Medical and scientific research:** VDUs are used in medical and scientific research to display data and images, such as MRI scans or microscopy images.
7. **Military and aviation:** VDUs are used in military and aviation applications to display maps, navigation information, and other data.
8. **Industrial and manufacturing:** VDUs are used in industrial and manufacturing settings to display production data, machine status, and other information.

Benefits of Visual Display Unit

Visual Display Units (VDUs), also known as computer monitors, offer a number of benefits, including:

1. **Improved productivity:** VDUs allow users to work more efficiently by providing a clear and easy-to-read display of text and graphics.

2. **Multitasking:** VDUs allow users to work on multiple tasks at the same time by displaying multiple windows or programs on the screen.
3. **High-resolution displays:** Some VDUs support high-resolution displays, which can provide a more detailed and accurate representation of the information being displayed.
4. **Connectivity:** VDUs may have connectivity options, such as HDMI or Display Port, which allow users to connect the VDU to other devices, such as a computer or a television.
5. **Easy to use:** VDUs are generally easy to use, with simple controls and an intuitive interface.
6. **Energy efficient:** Many modern VDUs are energy efficient, which can help reduce electricity consumption and reduce the environmental impact of using a computer.
7. **Customization:** VDUs can be customized to meet the specific needs of the user, such as adjusting the display settings to reduce eye strain or to optimize the display for specific tasks.
8. **Access to information:** VDUs allow users to access a vast amount of information and data that is stored on computers, which can be useful for research, education, and more.

Limitations of Visual Display Units (VDUs)

Visual Display Units (VDUs), also known as computer monitors, have a few limitations, including:

1. **Limited viewing angles:** Some VDUs have limited viewing angles, which means that the display may appear distorted or washed out if viewed from certain angles.
2. **Limited display size:** The size of a VDU is limited by the size of the screen, which may not be large enough to display certain types of information or graphics.
3. **Limited color depth:** Some VDUs may not support a wide range of colors, which can impact the accuracy and quality of the display.
4. **Limited refresh rate:** The refresh rate of a VDU refers to how often the display is updated, and a lower refresh rate can result in a less smooth and responsive display.
5. **Limited resolution:** The resolution of a VDU refers to the number of pixels on the screen, and a lower resolution can result in a less detailed and accurate display.

6. **Limited lifespan:** Like all electronic devices, VDUs have a limited lifespan and may need to be replaced after a certain period of time.
7. **Cost:** VDUs can be expensive, particularly high-end models with advanced features.
8. **Environmental impact:** The production and disposal of VDUs can have an impact on the environment, as they contain materials and chemicals that can be harmful if not properly managed.

Hazards of Visual Display Unit

There are a few potential hazards associated with using Visual Display Units (VDUs), also known as computer monitors, including:

1. **Eye strain:** Prolonged use of a VDU can cause eye strain, which can cause symptoms such as dry eyes, blurred vision, and headache.
2. **Repetitive strain injury:** Repetitive actions, such as typing or using a mouse, can cause repetitive strain injuries, such as carpal tunnel syndrome.
3. **Back pain:** Poor posture while using a VDU can cause back pain, particularly if the workstation is not set up correctly.
4. **Electromagnetic fields:** Some VDUs emit electromagnetic fields, which have been linked to an increased risk of cancer and other health problems. However, the risks associated with electromagnetic fields from VDUs are generally considered to be low.

EXAMPLES OF VDU



Cathode ray tube (CRT)



Digital / Multimedia Projector





LCD vs LED Displays: The Differences

When it comes to choosing between LCD and LED displays, the decision can often be confusing. At first glance, they may seem identical, but there are key differences in their construction, performance, and energy efficiency. In simple terms, LED displays are a type of LCD with a unique backlighting system, and they tend to offer better image quality and power efficiency than standard LCDs.

LCD Displays



LCD, which stands for Liquid Crystal Display, utilizes a panel of liquid crystal molecules to create images. These molecules twist and untwist to control the amount of light passing through them. However, they do not produce light on their own. Instead, they use a separate backlight or reflector to illuminate the liquid crystals.

The backlight in traditional LCD panels is often a Cold Cathode Fluorescent Lamp (CCFL). While these displays offer good image quality, they have some limitations. Generally, they consume more power and are bulkier than their LED counterparts. Moreover, they may not provide as high contrast or as vibrant colors.

LED Displays

LED, or Light Emitting Diode displays, are essentially a type of LCD display. The key difference lies in the backlighting system. Instead of using CCFL, LED

displays use tiny light-emitting diodes to illuminate the liquid crystals. This change in lighting source opens up a range of benefits.

Firstly, LED displays are more energy efficient. LEDs consume less power than CCFL, making them a greener choice. Secondly, they allow for a slimmer and lighter design, making them ideal for modern, sleek devices.

One of the critical advantages of LED displays is the potential for greater picture quality. In LED displays, the diodes can be dimmed or brightened individually. This feature, known as local dimming, enhances the contrast ratio, making blacks appear deeper and whites brighter. Consequently, images are more vibrant and lifelike.

PRINTERS

Different Types of Printers and Their Functions:



What Are the Types of Printers?

Thermal Transfer Printers

Thermal printers use heat to create an image on special thermal paper.

They provide direct thermal and thermal transfer, and they're commonly used in receipt printers, shipping label printers, and fax machines.

Additionally, they're fast, quiet, and don't require ink or toner. However, the print quality of a thermal printer may fade, and the paper can be expensive.

Dye-Sublimation Printers

Dye-sublimation printers use heat to transfer dye onto special paper or other materials like fabric or plastic. They're popular for high-quality photo printing and creating customized items like mugs and T-shirts.

Additionally, they produce vibrant, long-lasting prints with excellent color accuracy, but the cost of consumables (ink and paper) can be relatively high. And they're not ideal for standard office documents.

3D Printers

3D printers create three-dimensional objects by layering material (often plastic) on top of itself based on a digital 3D model.

They're used in various fields, including manufacturing, healthcare, and education, for rapid prototyping and custom parts production.

Furthermore, they can create complex shapes and prototypes, revolutionizing many industries. However, 3D printing can be slow for large objects, and the cost of materials can increase over time.

All-in-One Printers (Multifunction Printers)

Multifunction printers combine all the functions into one device, including printing, copying, scanning, and even faxing. They're versatile and space-saving, making them suitable for home and office use.

Moreover, they provide convenience by consolidating multiple tasks into one machine. However, some may not excel in every function, so it's important to choose one based on your specific needs.

Large Format Printers

Large-format printers, also known as wide-format printers, can produce much larger prints than standard document sizes. They're used for printing posters, banners, architectural plans, and artwork.

Additionally, they can produce oversized prints with high detail and quality. However, they're typically expensive and take up significant space.

Mobile Printers

Mobile printers provide on-the-go printing. They're compact and ideal for printing documents or photos directly from smartphones and tablets. The best part? They're also lightweight and can be used while traveling or in remote locations.

However, they may have limited paper capacity and print speed compared to larger printers.

Plotters

Plotters produce high-quality, large-scale graphics, such as engineering and architectural drawings. They're specialized printers commonly used in industries where precision and accuracy matter.

They can handle larger paper sizes and create detailed, accurate drawings. However, they're expensive and not suitable for typical office printing needs.

UV Printers

UV printers use ultraviolet light to cure inks or coatings instantly, making them suitable for printing on various materials, including glass, wood, and metal. They're used for creating signage, promotional items, and customized products.

The best part? UV printing offers vibrant colors and durability on various surfaces. However, initial equipment costs can be high, and maintenance may be needed to keep the printer functioning optimally.

Digital Presses

Digital presses make a great choice for commercial printing and publishing. They're high-volume printing machines suitable for large quantities of books, brochures, and other printed materials.

They offer fast, consistent, high-quality printing for large print runs. However, they're expensive and may require specialized training to operate effectively.

In summary, there's a wide array of printers, each designed for specific purposes and printing needs. Choosing the right printer depends on the type of documents or images you need to print, the printing volume, and your budget.

Consider your requirements carefully to select the printer that best suits your needs, whether for everyday home use, office tasks, creative projects, or industrial applications.

Other Types of Printers

9. Plotters



Calculator Plotter

HP 9862A

Example: HP Design Jet T210

A plotter prints vector graphics by drawing lines on paper using a pen. Some plotters use markers to draw multiple, continuous lines onto paper, while some use knives to cut a material like leather or vinyl. The latter is called cutting plotters.

These devices have been phased out by computer-controlled printing machines. However, cutting plotters are still used in many industries.

Pros

- Prints on large sheets of paper with high resolution

- Draws a single pattern more than one thousand times with no degradation
- Works with various materials, including cardboard, plywood, plastic, and aluminum

Cons

- Expensive and larger than a conventional printer

8. Impact Printers

The impact printer physically presses an inked ribbon against the page. Its plastic or metal head strikes the ink ribbon, whereby the ribbon is pressed against the page, and the specific character impression is printed on the paper. Although this mechanism is quite old, impact printers are still widely used in workplaces and industries.

Many different types of impact printers have been developed to date. The most common ones are:

8.1 Line Printers



IBM 1403 line printer

Example: Printronix P7-1500N line matrix printer

As the name suggests, Line printers print one line of text at a time (the full width of the page). They use a continuous feed of paper instead of individual cut sheets. And they can print up to 2,500 lines per minute.

Pros

- High-speed printing
- More durable
- Low operating costs
- Consumables are less harmful to the environment

Cons

- Low print quality and cannot print graphics
- Very noisy, requires sound-absorbing cases

8.2 Dot Matrix Printers



310

Epson LX-

Example: Tvs MSP 250

In a dot matrix printer, the pins are arranged in one or multiple vertical columns. The print head (which contains several pins) moves up and down or in a back and forth motion and prints by striking an ink-soaked cloth ribbon against the page. This is just like a typewriter, but it can also print arbitrary patterns and not just particular characters.

A character printed by a dot matrix printer is actually an accumulation of multiple dots on a very small region of the paper. The printer can be used for text, multiple fonts, and basic graphical printing. The outputs, however, have a “dotted” appearance.

Pros

- Low printing cost
- Reliable
- Prints on multipart forms or carbon copies
- Useful for data logging

Cons

- Slow speed
- Limited print quality

They can be used to print multiple copies at the same time with the help of carbon copying. Thus, they are widely installed in offices and shops where multipart forms are required.

8.3 Daisy Wheel Printers

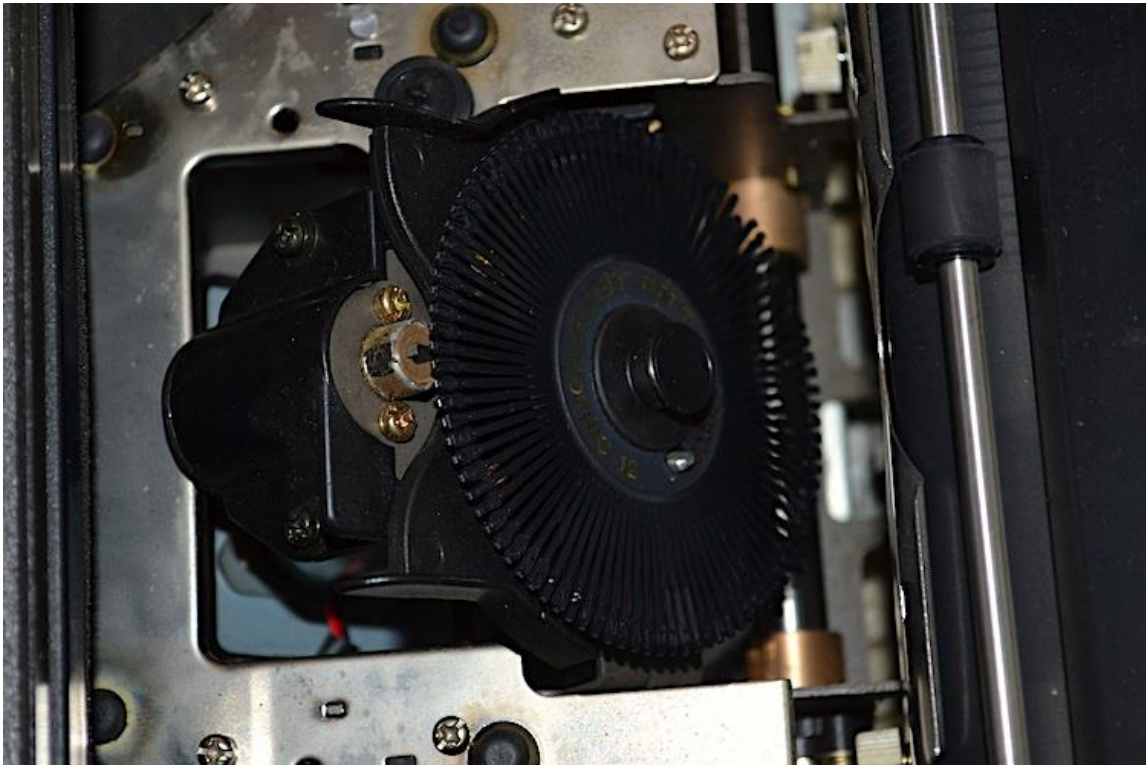

The daisy wheel and print head on a Diablo D-25 printer

Example: Commodore DPS 1101

A daisy wheel printer contains a disk and attached extension on which molded metal characters are mounted. When printing, the printer rotates the disk to each character and strikes it into an ink ribbon to create characters on paper.

Pros

- Can use heavy paper grades and fan-fold paper
- Can create carbon copies
- Low costs and maintenance

Cons

- Slow speed
- Low print quality

7. Minilab Printers



D870

SureLab

Example: Epson Sure Lab D1070DE

Minilabs are small photographic-developing and printing systems that are used in several retail stores to provide quick photo finishing services. A minilab machine is made of two systems: a film processor and a printer (paper processor).

Pros

- Perfect for photo processing
- High-capacity ink packs
- Prints on double- or single-sided sheet media
- Provides better exposed, color-corrected prints in less than 30 minutes

Cons

- Quite pricey
- Larger and bulkier and than typical printers

The Agfa and Kodak minilab machines use C41b chemistry to process films and RA-4 chemistry to process the paper. Depending on the device capabilities and operator's expertise, films can be ready for collection within 20 minutes.

6. Thermal Printers



thermal printer

F2C portable

Example: Polono Label Printers

A thermal printer is made of three components:

- Thermal head: Generates heat to produce an image on the page
- Platen: A roller that moves the page
- Spring: Holds the printhead and paper together by applying small pressure

The printer passes paper with a thermochromic coating over a print head. This print head contains several electrically heated elements, typically arranged as a line of small, closely spaced dots. The coating on the paper turns black in the region where it is heated, generating an image.

These printers can have a resolution of up to 1,200 DPI. Although most of them print black and white (monochrome) text, some produce two-color images.

Due to decent print quality, speed, and portability, thermal printers are widely used in the banking, retail, grocery, healthcare, and airline industries. Voucher printers in slot machines, information kiosks, and point of sale systems are some of the commercial applications of these printers.

Pros

- More quiet and faster than dot matrix printers
- Easier to use as there is less use of software involved
- Requires less maintenance
- Comes in various models and sizes

Cons

- Prints fewer colors
- The high heat limits wax and resin choices

They are also used to generate sub-seafloor seismic imagery and print real-time records of side-scan sonar. In the data processing field, they are used for quickly creating hard copies of continuous hydrographic or seismic records.

5. Dye-sublimation Printers



RT-640

Texart

Example: Texart XT-640 High-Volume Dye-Sublimation Printer

Dye-sublimation printers utilize heat to transfer dye onto materials like card, paper, fabric, or plastic. They use the CMYO (cyan, magenta, yellow, over coating) system to deposit the ink on the surface one color at a time. The ink is deposited via a heat press, which ultimately changes from solid to gas (hence the name “sublimation”) and enters the material.

The process is carried out at lower temperatures and higher pressures. Small heating elements on the print head change temperatures quickly to lay different amounts of dye. Polyester and polyester resin-coated substances are the perfect materials for this printing technique.

Pros

- Allows printing on rigid surfaces
- Print thousands of colors using four-color ink (CMYK)
- Best for creating ID cards and photographic prints
- Short learning curve

Cons

- The item may lose color over the months
- Specific type of ink is required

Professional and consumer dye-sublimation printers are developed for creating photographic prints, ID cards, license plates, etc. And since these printers are available in various sizes and styles, consumers can print on various products like mouse pads, coffee mugs, handbags, smartphone cases, dresses, pillows, and more.

4. Solid Ink Printers



Example: HP Laserjet M209DW

As the name suggests, these printers use solid ink instead of fluid ink or toner powder. The printer melts the ink (which is usually a waxy resin-based polymer) to print images on paper or any substrate.

This is how the process goes: small pucks or spheres of solid ink are stored in a hopper. From there, they are transferred to the printhead and melted as per the requirement.

Pros

- Provides precise prints with bright colors
- Can print on many different types of media
- Less waste generated compared to inkjet or laser printers
- Suitable for intermittent use with long periods of downtime

Cons

- The printer need to pause and reheat in between prints
- Ink may clog printhead nozzles

This type of printer can create large graphic images with bright and vivid colors at reasonable costs. It is suitable for users who always have to print in color and require high-quality images. And since the solid ink doesn't dry out over time, you don't have to order new cartridges when you need to print something after a long time.

3. 3D Printers



I3 MK3S

Prusa

Example: Tronxy X5SA Pro

3D printers are based on a technique called additive manufacturing. They create a physical three-dimensional object from a CAD (computer-aided design) or digital model. It involves adding materials (such as powder grains or composites or bio-materials) layer by layer at the millimeter scale.

Unlike injection molding and CNC machining that uses various cutting tools to make objects, 3D printers require no cutting tools. They construct objects directly onto the built platform.

Pros

- Enables fast design and production
- Gives you the flexibility to create anything that fits within its build volume
- Minimize waste
- Cost-effective

Cons

- Not yet versatile enough to work with most materials
- Requires post processing

Depending on the type of printer, material used, and size of the object, a print takes several hours to complete. The finished object often requires post-processing (like sanding, paint, or other conventional finishing touches) to achieve the desired surface finish.

3D printing processes can be categorized into 7 groups:

1. Vat photo polymerization
2. Material Extrusion
3. Sheet Lamination
4. Directed Energy Deposition
5. Material Jetting
6. Binder Jetting
7. Powder Bed Fusion

Modern 3D printers are advanced enough to create complex structures and geometries that would be otherwise impossible to build manually. They can be used to build a range of objects, from simple prototypes to intricate final products, such as medical instruments, aircraft parts, eco-friendly buildings, and even artificial organs using layers of human cells.

2. Liquid Inkjet Printers



HP Smart Tank 530

Example: Canon PIXMA G3260

The inkjet printer creates an image by propelling droplets of ink onto paper or plastic substrates. Its print head moves back and forth as the paper feeds through rollers. The complete image is made of thousands of minuscule dots, like the pixels on a television screen.

These dots are extremely small (between 50 and 70 microns in diameter) and positioned very precisely with resolutions up to 1200 x 1440 DPI. Also, these dots can have multiple colors combined together to produce high-quality pictures.

Pros

- Quieter than impact printers
- Practically no warm uptime
- Really good at producing natural shades and colors
- Easy to set up and use

Cons

- Liquid ink can dry out when stored for a longer period of time
- Expensive ink refills

Liquid inkjet printers perform best on nonporous paper and slightly heavy bond paper with a hard surface that effectively prevents colors from bleeding. They are available in many different varieties and sizes, ranging from small cost-efficient consumer models to expensive professional machines. While most home inkjet printers are lightweight and have low per-page costs, commercial machines are larger and print on a broader range of materials.

1. Laser Printers



Example: HP OfficeJet 5255

Laser printers have become a common consumer product, often used along with personal computers. Their working principle involves electrophotographic, which is the same technique used in photocopy machines.

To create a high-quality image, the laser printer continuously passes a laser beam back and forth over a photoreceptor drum. This drum is nothing but a negatively charged cylinder. It collects positively charged

powdered ink (toner) and transmits the image to paper. The paper is then slightly heated to permanently fuse the image onto it.

The standard resolution in most laser printers is 600 DPI, whereas the high-end production machine can have a resolution of 2,400 DPI. Plus, they can print at a much faster rate than inkjet printers. A high-end model can print about 12,000 monochrome pages per hour or 6,000 colored pages per hour.

However, they don't print color photos as well as inkjet printers do. That's why most photographers and designers prefer inkjet printers for gallery-quality photos.

Pros

- Fast printing speed
- Noiseless
- Produces high-quality monochrome prints
- Mechanical components are reliable and durable

Cons

- High initial investment cost
- Not suitable for high quality graphics

Laser printers are well suited for office use due to their capability to quickly print large amounts of documents. Overall, they are excellent for text, documents, and printing medium-quality color photos

1.1 LED Printers



Example: Xerox VersaLink C7000DN

LED (light-emitting diode) printers are generally grouped with laser printers because they use a similar technique for creating text or graphics. Both use a toner, drum, and fuser to provide high-quality prints. However, LED printers have an array of light-emitting diodes instead of a laser and mirror.

Since LED printers contain fewer moving parts, they are more reliable and efficient than traditional laser printers. Plus, they are cheaper to manufacture and less prone to mechanical wear.

Pros

- Contains fewer moving parts
- Inexpensive and reliable
- Noiseless
- Provides excellent image quality

Cons

- High initial cost
- Slower printing speed than laser printers

Factors to consider when selecting a printer

Choosing the best printer can be overwhelming with so many options. To help you decide which type of new printer you should buy, consider the following factors and your specific needs:

Printing Purpose

Home Use: If you need a printer primarily for occasional home use, like printing documents, school assignments, or family photos, an inkjet printer should suffice. They're affordable and can handle a variety of printing tasks.

Small Businesses: A laser printer is a good choice for a small office or home office (SOHO) where you must print frequently. It offers fast and efficient text printing.

Color or Black and White

Consider an inkjet or color laser printer if you need to print in color. For basic black-and-white documents, a monochrome laser printer is cost-effective.

Print Volume

For bulk printing, a laser printer with a high page-per-minute (PPM) rate and a large paper tray may be more suitable. Inkjet printers make a better choice for lower print volumes.

Printing Photos

If you're into photography and want to print photos, a dedicated photo printer or a high-quality color inkjet printer with photo capabilities is a good choice. Consider other costs like glossy photo paper for the printing process, maintenance, etc.

Size and Space

Consider the available space where you plan to put the printer. Consider a compact inkjet printer if you have a small space, as laser printers can be larger.

All-in-One or Single Function

An all-in-one (a multifunction printer) combines printing, copying, scanning, and even faxing in one machine. It's convenient for saving space and money if you need these functions.

Connectivity Options

Ensure the printer you choose has the connectivity options you need. Common features include USB, Wi-Fi, Bluetooth, and mobile printing capabilities.

Cost Considerations

Think about both the upfront cost of the printer and the long-term cost of consumables like ink or toner cartridges. Some printers may be inexpensive initially but cost more to maintain.

Brand and Model

Consider reputable brands known for quality and reliability. Read reviews and compare printer models within your budget.

Additional Features

Some printers have extra features like automatic duplex (double-sided) printing, touchscreen controls, and memory card slots for direct photo printing. Assess whether these features matter to you.

Compatibility

Ensure the printer is compatible with your computer's operating system. Most modern printers support Windows and macOS, but it's always good to check.

Warranty and Support

Check the warranty, warranty extensions, and available customer support for the printer. Extremely reliable customer service can be crucial if you encounter any issues.

Environmental Considerations

If you're eco-conscious, look for printers with energy-saving features, recyclable ink or toner cartridges, and eco-friendly certifications.

In summary, the type of printer you should buy depends on your specific needs and budget.

Consider your printing volume, fast print speeds, whether you need color printing, available space, and any extra features for high-quality prints you require. It's also a good idea to read reviews and compare prices before deciding.

Considering these factors, you can find a printer that suits your print jobs and helps you achieve your printing goals efficiently.

How to Print a Document from Your Computer

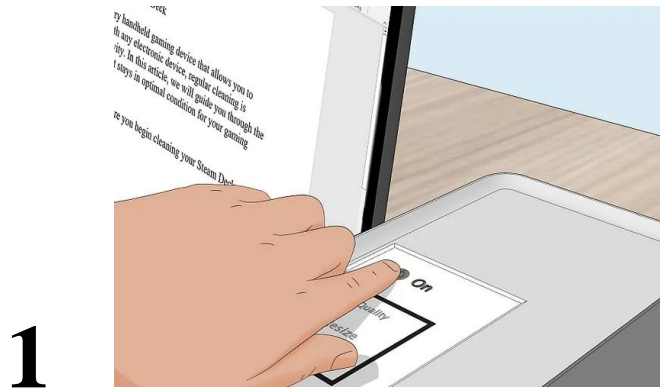

Make sure that your printer is connected and turned on. If your printer connects over Wi-Fi, this will mean making sure that you're on the same Internet network as your printer; otherwise, you'll need to plug your printer's USB cable into your computer.

- Check your printer's manual to confirm how to set it up if you haven't already done so.
- Be sure to update your printer drivers.

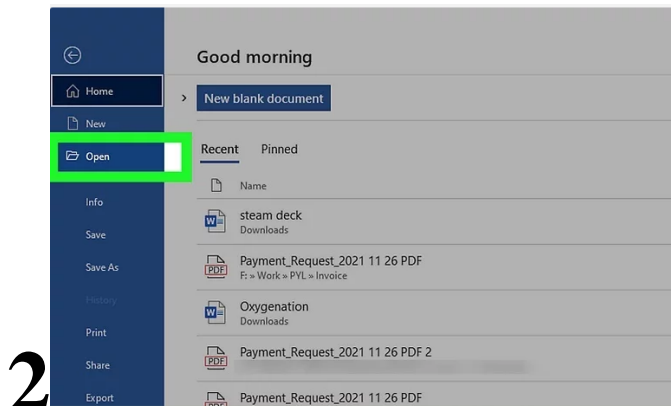

Open the document you want to print. This could be a PDF, Word document, Excel spreadsheet, or even photos.

- Use the File Explorer to find the file if needed.



On your keyboard, press **Ctrl + P**. This is the keyboard shortcut to open the print menu.

- You can also manually open the print menu by clicking the printer icon.
- In some apps, you'll need to click **File** and then **Print**.
- The print menu may look different depending on the application used to open your file.

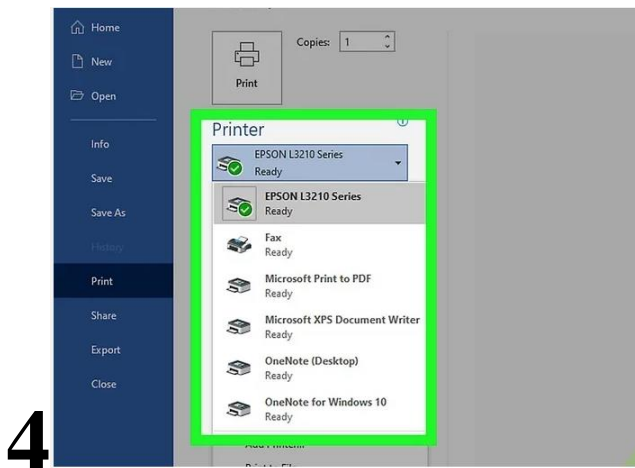

Select your printer. Click the "Printer" drop-down box, then click your printer's name.

- If you don't see your printer, you'll need to add it.

5

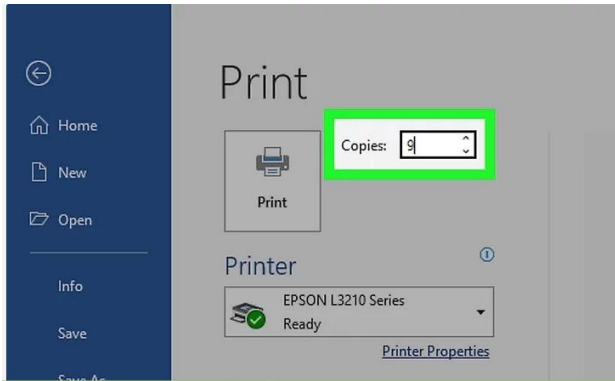

Select a number of copies. In the "Copies" box, type in the number of copies of the document that you'd like to print.

- This is different than the number of pages.

6

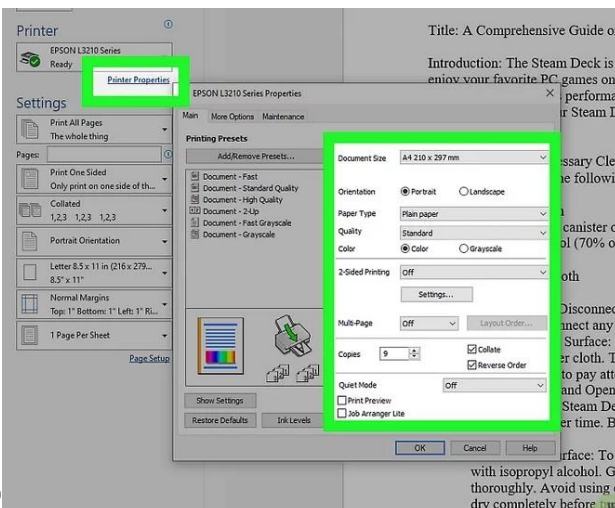

Edit other print settings. The menu for each document type will vary, but you'll have the following options for most documents:

- **Orientation:** Determine whether your document is oriented vertically or horizontally.
- **Color:** Decide between printing in black and white or including color printing. You must have colored ink in your printer to print in color.
- **Number of sides** - Choose single-sided printing to print one sheet of paper per page, or choose double-sided printing to use both sides of a piece of paper.

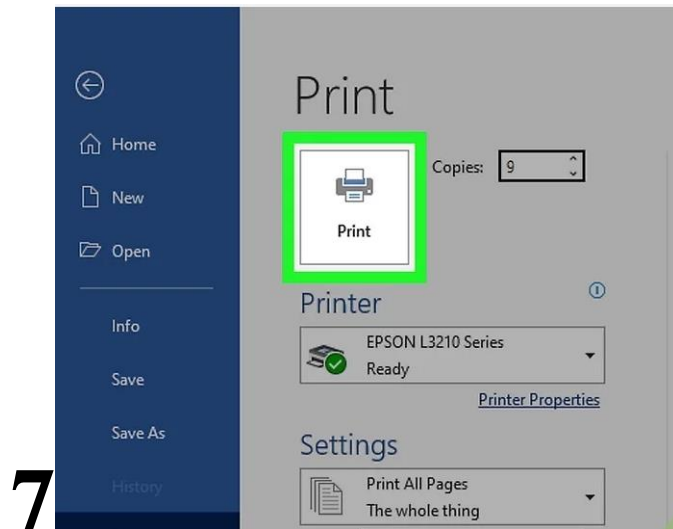

Click **Print**. It's either at the bottom of the window or at the top of the window. Your document will begin printing.

COMPUTER MEMORY

Types of Computer Memory

Memory is an essential component of the computer. It is a hardware device that assembled on the motherboard for storing data and instructions for performing a task on the system. Two types of memory are used by the computer, one for storing data permanently and second for operating.

Types of Memory

Primary memory

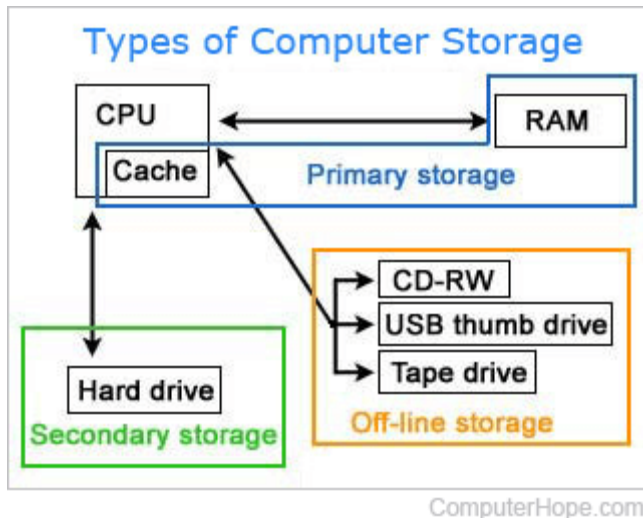

A **primary storage device** is a medium that holds memory for short periods of time while a computer is running. Although it has a much lower access time and faster performance, it is also about two orders of magnitude more costly than secondary storage.

RAM (random-access memory) and cache are both examples of a primary storage device. The image shows three different types of storage for computer data. Primary storage's key differences from other storage devices are that it is directly accessible by the CPU (central processing unit), is volatile, and is non-removable.

Tip

A primary storage device may also be called **internal memory**, **main memory**, **main storage**, and **primary memory**.

RAM (random access memory)

What is RAM

Ram full form” random access memory” and is **volatile**. First we’ll tell you what RAM memory alternatively referred to as *main memory*, *primary memory*, or *system memory*, **Random Access Memory** (RAM) in a computer system, it is also sometimes known as read-write memory or **RWM**, then we’ll go over how RAM works in Macintosh’s and pcs. Also, there are different kinds of RAM, including *VRAM*, *PRAM*, *DRAM* and *SRAM* .

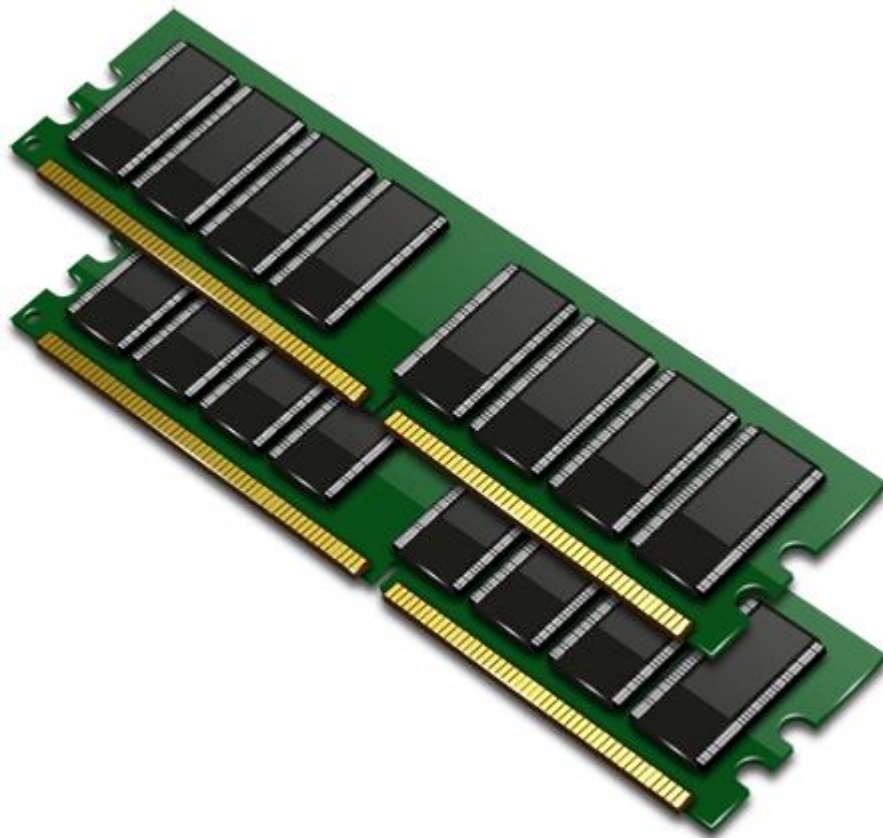

Random access memory (RAM)

This is the most common type of main memory. It is called random access memory (RAM) because ; its content can be read directly

regardless of the sequence in which it was stored. As opposed to ROM, the content in RAM is held temporarily and its content is lost once the computer is turned off.

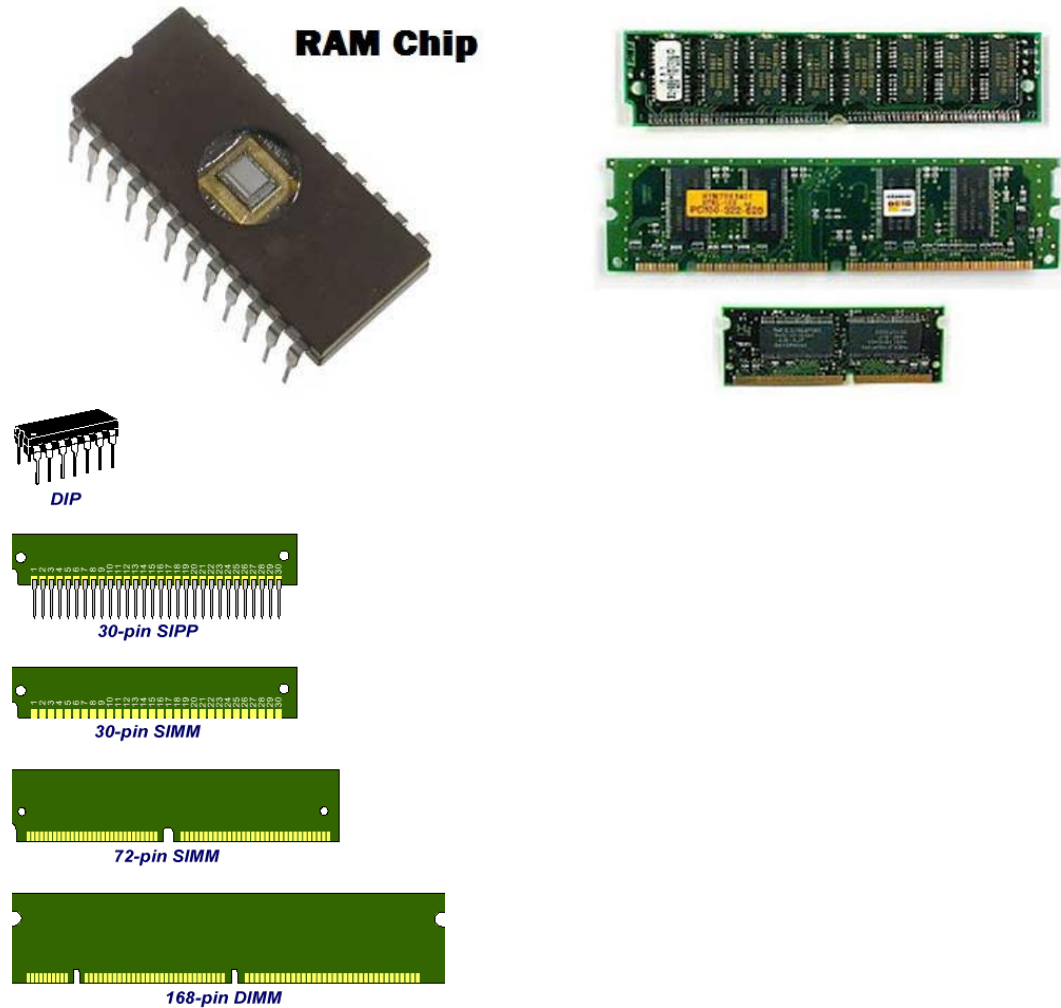

Characteristics of random access memory (RAM) are:

- 1.Data can be read(retrieved)and written(stored) in it.
- 2 .RAM is a temporary (volatile) storage because its content disappears when the computer is switched off.
- 3.Its content is user defined i.e. the user dictates what is to be contained in the RAM.

Types of RAM

There are two types of-RAM namely, *static RAM (SRAM)* and *dynamic (DRAM)*. Static RAM is very fast compared to dynamic RAM and holds its content as long as there is power. Dynamic RAM on the other hand can only hold its content for a short while even when power is all .To maintain the content of dynamic RAM, the memory chip is designed in away that its content is refreshed (automatically rewritten) severally per second. Static RAM is more expensive. It is mostly used to make special types of memories.

Special purpose memories

Apart from ROM and RAM there are several types of special purpose memories found inside the CPU or in the input and output devices.

These memories are vital because they increase the overall performance of data and instructions moving in and out of the CPU. These memories include *buffers*, *registers* and *cache memory*.

Buffers

This is a temporary holding place that may be part of the CPU or built in an input or output device. Because the CPU is very fast compared to the input or output devices, buffers provide temporary storage so that the CPU is set free to carry out other activities instead of waiting for all data to be entered or information to be output. For example since a printer cannot work at the speed of a CPU, the printer buffers temporarily holds the output to be printed hence freeing the CPU to perform other functions. Buffers can hold more than one piece of data at a time.

Registers

As opposed to buffers, registers hold one piece of data at a time and are inside the CPU. Examples of registers are:

An accumulator: This temporarily holds the results of the last processing step of the ALU.

Instruction register: This temporarily holds an instruction just before it is interpreted into a form that CPU can understand it.

An address register: This temporarily holds next piece of data waiting to

be processed.

Storage register: This temporarily holds a piece of data that is on its way to and from the CPU and the main memory.

Cache Memory

Most modern processors incorporate small high-speed type of SRAM called cache memory. The purpose of cache memory is to allow the processor to access data and instructions even faster than it would have taken to fetch it from the relatively slow DRAM.

Read Only Memory. ROM

ROM Definition: It is an example of nonvolatile memory. **ROM full form is Read Only Memory.** It is a class of storage medium used in computers and other electronic devices. *Read Only Memory (ROM)*, also known as firmware, is an integrated circuit programmed with specific data when it is manufactured. The instructions for starting the computer are housed on Read only memory chips.

Characteristics of read only memory (ROM) are;

1. One can only read its content but you cannot write on it unless it is a special type of ROM.
2. It is non-volatile i.e. its content is not lost when the computer is switched off
3. Stores permanent or semi-permanent instructions from the manufacturer called firmware. It can store semi-permanent instructions because some variations of ROM chips can be programmed according to the users specification.

Types of ROM :

PROM : Short for programmable read-only memory, a memory chip on which data can be written only once. Once a program has been written onto a PROM, it remains there forever. Unlike RAM, PROMs retain their contents when the computer is turned off. The difference between a PROM and a ROM (read-only memory) is that a PROM is manufactured as blank memory, whereas a ROM is programmed during the manufacturing process. To write data onto a PROM chip, you need a special device called a PROM programmer or PROM burner. The process of programming a PROM is sometimes called burning the PROM.

EPROM : Acronym for erasable programmable read-only memory, and pronounced ee-prom, EPROM is a special type of memory that retains its contents until it is exposed to ultraviolet light. The ultraviolet light clears its contents, making it possible to reprogram the memory. To write to and erase an EPROM, you need a special device called a PROM programmer or PROM

burner.

EEPROM : Short form of electrically erasable programmable read-only memory. EEPROM is a special type of PROM that can be erased by exposing it to an electrical charge. Like other types of PROM, EEPROM retains its contents even when the power is turned off. Also like other types of ROM, EEPROM is not as fast as RAM.

Difference between RAM and ROM

Difference between ram and rom

- ROM can hold data permanently and RAM cannot.
- ROM chip is a non-volatile and RAM chip is volatile in nature.

Memory Capacities

Memory Capacities

Memory and storage capacity is measured in special units called bytes. A byte is equivalent to a single character. Characters can be a number from 0 to 9, letters A to Z or a special symbol. For example, a number like 2545 has four bytes while the words ,My Home has seven bytes since the space between them has 1 byte.

Memory capacities can be expressed in;

Kilobytes (KB): Approximately one thousand bytes.(1024)

Megabytes(MB):Approximately one million bytes.(1000 000)

Gigabytes(GB): Approximately one billion bytes.(1000 000 000)

Terabytes(TB): Approximately one trillion bytes.(1000 000 000 000)