

# KENYA JUNIOR SCHOOLS ASSESSMENT

## FORMATIVE ASSESSMENT TEST

### RUBRICS

1-29-BE

30-49-AE

50-79-ME

80-100-EE

TICK

GRADE

8

## INTEGRATED SCIENCE

### Marking scheme

1. Name three components of the atom. (3 mks)
  - a. Protons
  - b. Neutrons
  - c. Electrons
2. Name the three states of matter;
  - a. Solids
  - b. Liquids
  - c. gases
3. write the symbol of the following elements.(3 mks)
  - a. oxygen-O
  - b. magnesium-Mg
  - c. lead-Pb
  - d. iron -Fe
4. write the word equation for the reaction between oxygen and hydrogen.(2 mks)  
Hydrogen + Oxygen=Water

5. Fill in the table below appropriately

	characteristics		
	SHA	VO	MA
SO	✓	✗	✓
LI	✗	✓	✓
GA	✗	✗	✓

6. List four characteristics of gases

- Expands when heated
- Cannot be compressed
- Have definite volume
- No definite shape
- No definite mass
- Contract when cooled
- Have weight
- Occupy space

7. In the diagram below, the pupils observed and concluded that gases....

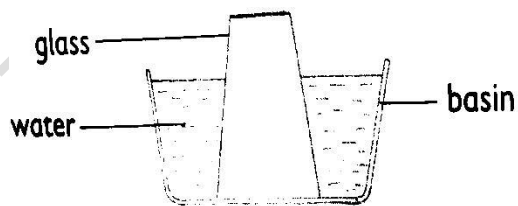

(b) Water has risen and has not entered the glass.

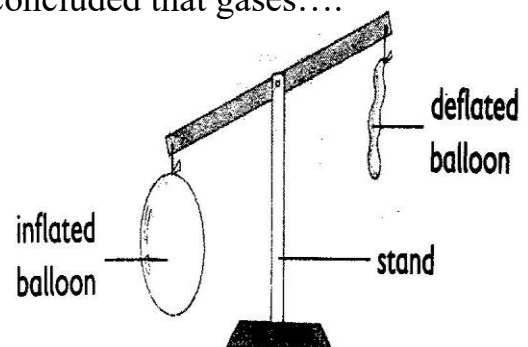

Gases occupy space

gases have weight

8. State two major factors that affects the state of matter?

- Temperature
- Pressure

9. Observe the diagram below and identify the indicated processes of change of state;

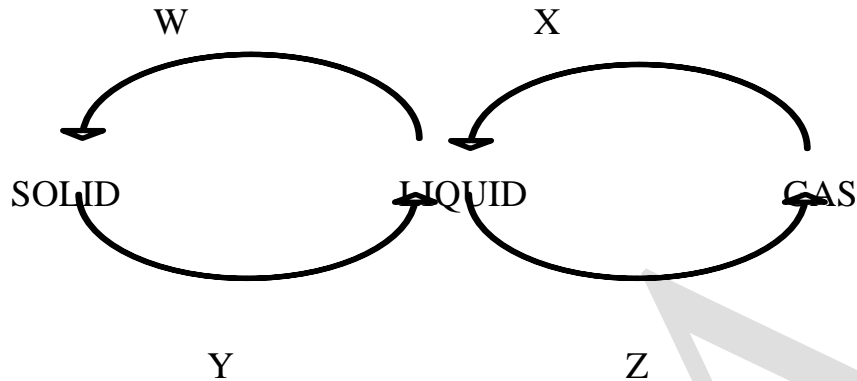

W= freezing

X= condensation

Y= melting

Z= evaporation

10. Name three processes that require a decrease in temperature.(3 mks)
- Condensation
  - Freezing
  - deposition
11. Ole Kinyasa from Hope Junior School boiled water as shown in the diagram below and later noticed that there were some water droplets under the lid when he cooled the water. This demonstrates the process condensation. (1 mk)

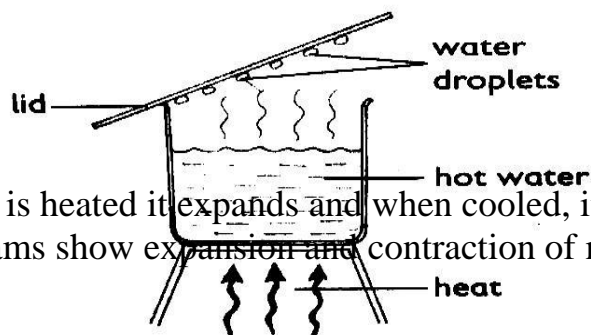

12. When matter is heated it expands and when cooled, it contracts. The following diagrams show expansion and contraction of matter. Identify each category.

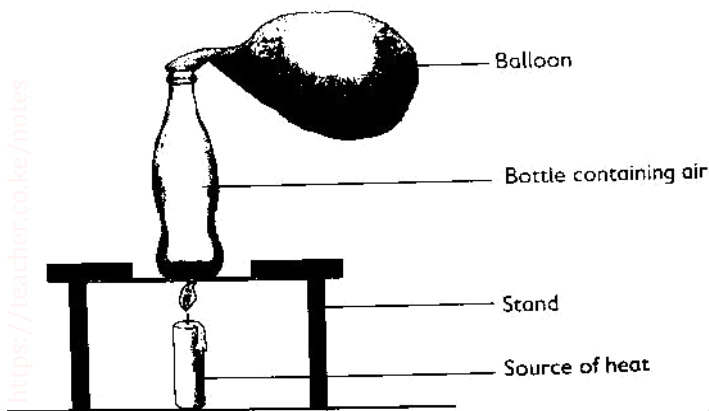

A

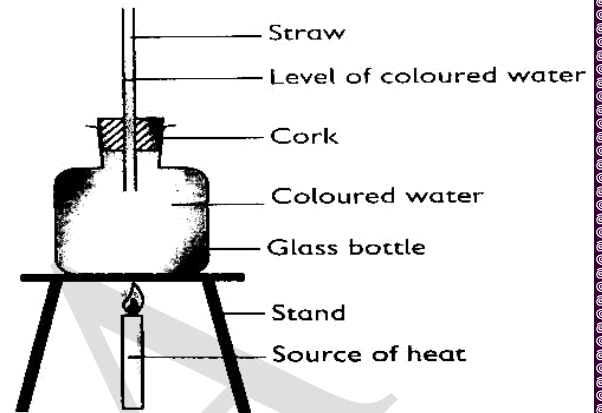

B

a. The above experiments demonstrate?

A

Expansion and contraction in gases

B

Expansion and contraction in liquids

13. Name three processes that requires an increase in temperature. (3 mks)

- Melting
- Evaporation
- sublimation

14. Name three acid-base indicators apart from plant extracts. (3 mks)

- litmus solution/paper
- phenolphthalein
- Methyl orange

15. Mafuta conducted the experiment as demonstrated below.  
What was he trying to find out?

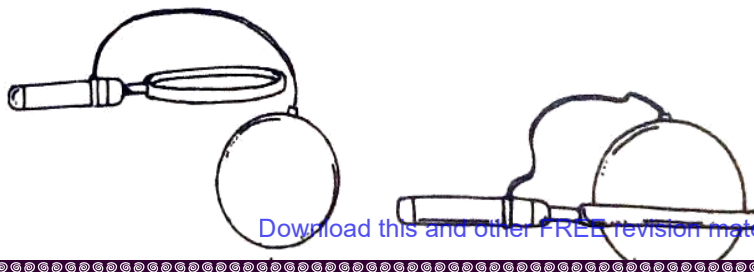

## Expansion and contraction in Gases.

16. The following pie chart represents various gases that constitute air. Indicate the gases and their percentages represented by the portions indicated on the pie chart.

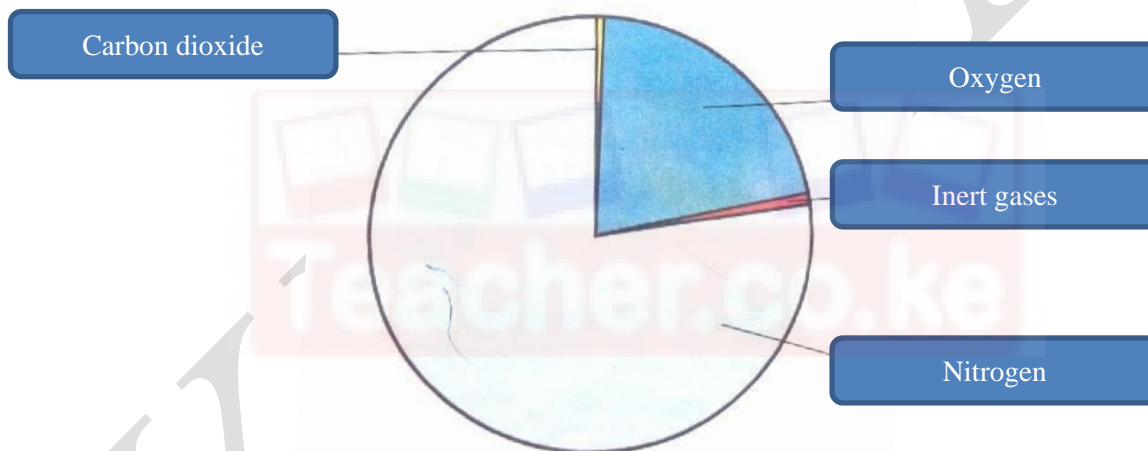

17. The following table represents basic quantities. Write their SI units and their symbols.(5 mks)

	quantity	SI Unit	Symbol
1	Length	<b>Metres</b>	<b>M</b>
2	Mass	<b>Grammes</b>	<b>g</b>
3	Time	<b>Seconds</b>	<b>s</b>
4	Electric current	<b>Amperes</b>	<b>A</b>
5	Temperature	<b>Kelvin</b>	<b>K</b>

6	Amount of substance	Mole	mol
7	Luminous intensity	Candela	Cd

18. Name the following parts of the light microscope.( 3 mks)

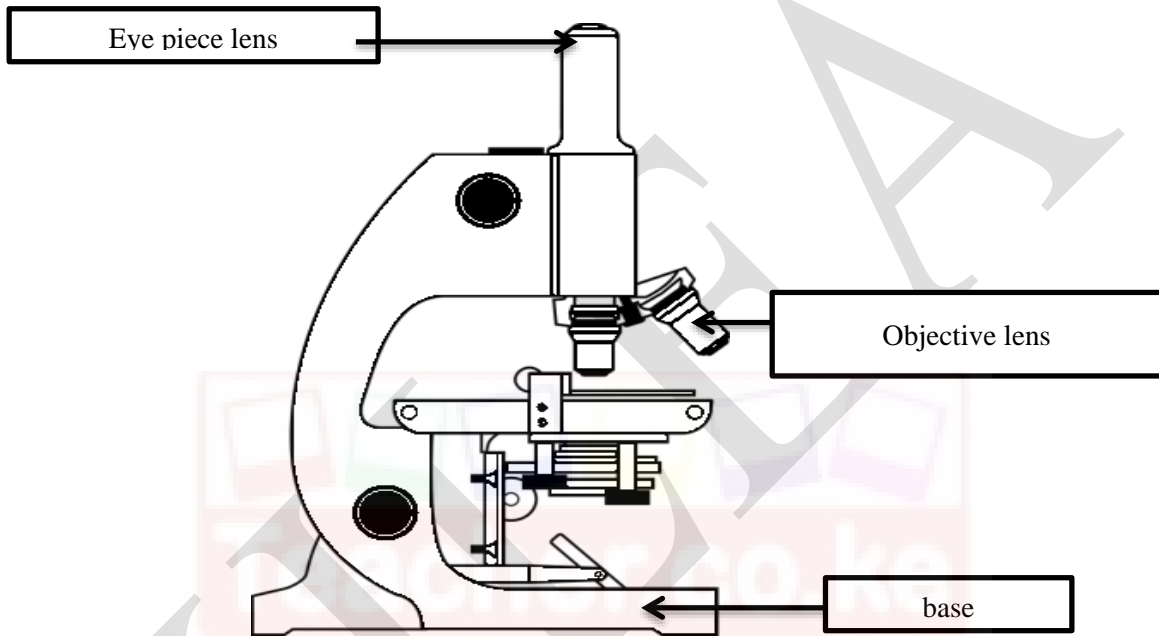

19. What is the meaning of the following sign?( 3 mks)



Biohazard



High voltage

20. Calculate the area of the following object.( 3 mks)

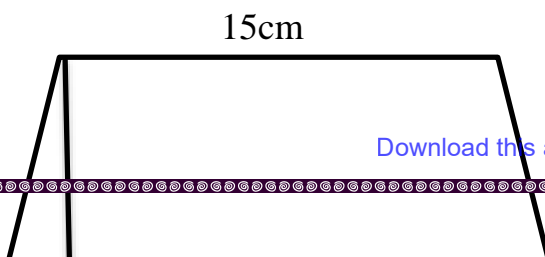

Area =  
 Area = 1/2 (sum of parallel side) x  
 perpendicular distance between the  
 sides  
 = 1/2 (a+b)h

$$A = \frac{1}{2} (a + b)h$$



10cm

12cm

$$= \frac{1}{2} * 10\text{cm} * (15\text{cm} + 12\text{cm})$$

$$= 135\text{cm}^2$$

21. Mention two rules you must observe when in the laboratory. (2 mks)

- a) Work carefully as carelessness can cause accidents as well as inaccurate results.
- b) Wear gloves, laboratory aprons and safety glasses.
- c) Never eat or drink in the laboratory.
- d) Tie back loose hair, roll back and secure open sleeves and neckties and make sure you wear shoes that fully cover your feet.
- e) Do not carry out laboratory experiments at home or in the dormitories unless directed to do so by your class teacher.
- f) Carefully read chemical labels and understand the hazard symbol on them.
- g) Listen carefully to your teacher's instructions on when and how to use safety equipments such as glasses, protective aprons, fire extinguishers and fire blankets.
- h) Make sure you know where the nearest fire alarm is in your school laboratory.
- i) Do not begin an experiment until the teacher instructs you to do so.
- j) Do not touch substances unless the teacher instructs you to do so. What looks harmless may be dangerous.
- k) Wash your hands with soap and running water after handling chemical substances. Some chemical substances are poisonous.
- l) Heat materials in suitable containers only, such as Pyrex glass container that can resist breakage.
- m) Always keep the open end of the test tube pointed away from the learners and yourself when heating chemicals because the fumes produced may be harmful.
- n) Pick up hot objects carefully using tongs or insulated materials.
- o) Make sure that you turn off the heat source when not in use to conserve energy.
- p) Always unplug electric cords by pulling out the plug and not the cord.
- q) Check that there are no flammable substances near the burner. Flammable substances will cause fire if exposed to a flame.
- r) After each experiment, tidy up your working area, clean all equipment and put

them in their respective storage areas.

- s) Report any accidents, broken equipment and damaged facilities to your teacher. In this way, you will be taking responsibility for your safety and for those who use the laboratory after you.
- t) If a chemical gets into your eyes, wash it out with running water for about 12 minutes and then visit a health centre or hospital for further medical attention.
- u) If you inhale poisonous gases or vapour, move outside the laboratory for fresh air. Immediately seek medical assistance.
- v) In case of electric shock immediately cut off the electric power source using an insulated object.
- w) In case of a fire outbreak, use sand, fire blankets and fire extinguishers to put out the fire.

22. Name two heat instruments used in the lab for heating purposes. (2 mks)

- a. Portable burner
- b. Bunsen burner
- c. Candle
- d. Spirit lamp

23. Identify the following lab apparatus. (3 mks)

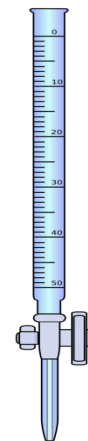
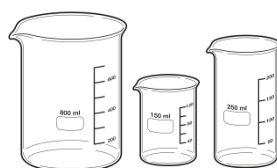
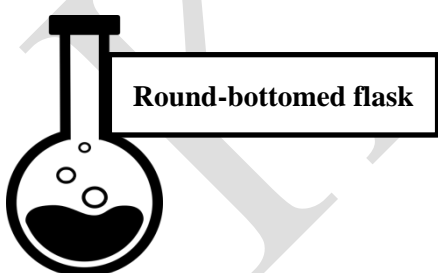

24. The volume of 2355g of glass was found to be  $50\text{cm}^3$ . Calculate the density of mercury (2 mks)



$$\text{Density} = \frac{\text{mass}}{\text{volume}}$$

$$D = \frac{2355g}{50\text{cm}^3}$$

$$D = 47.1\text{g/cm}^3$$

Download this and other FREE materials from <https://teacher.co.ke/notes>

KLLEA

